

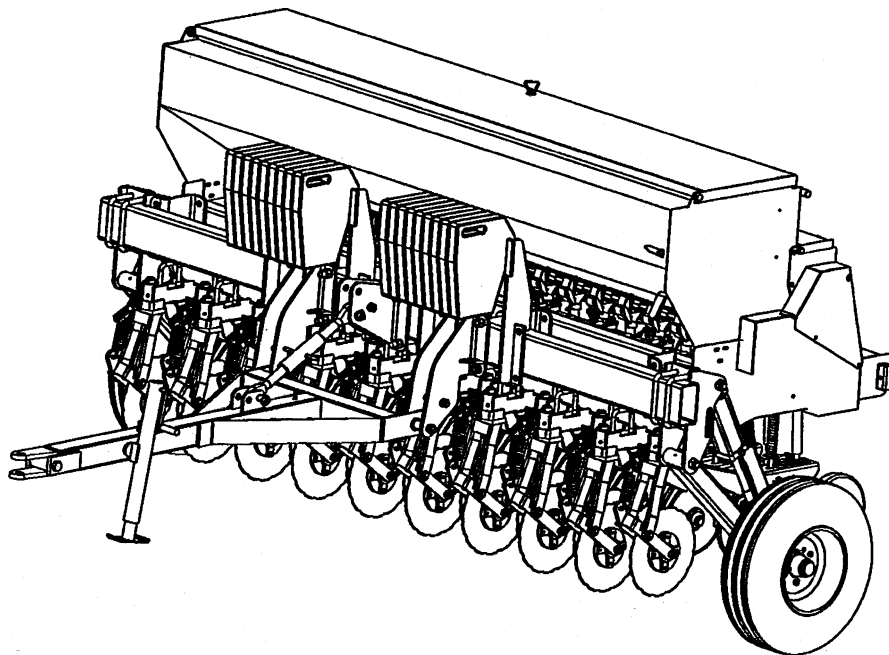

# MODEL 2055 & 2100

# DRILL

7', 10' & 12'



## Operation and Parts Manual

Remlinger Manufacturing Company, Inc.  
16394 U. S. 224 • P.O. Box 299 • Kalida, Ohio 45853  
Toll Free: 800.537.7370

[www.remlingermfg.com](http://www.remlingermfg.com)

# SPECIFICATIONS

## 3-POINT HITCH

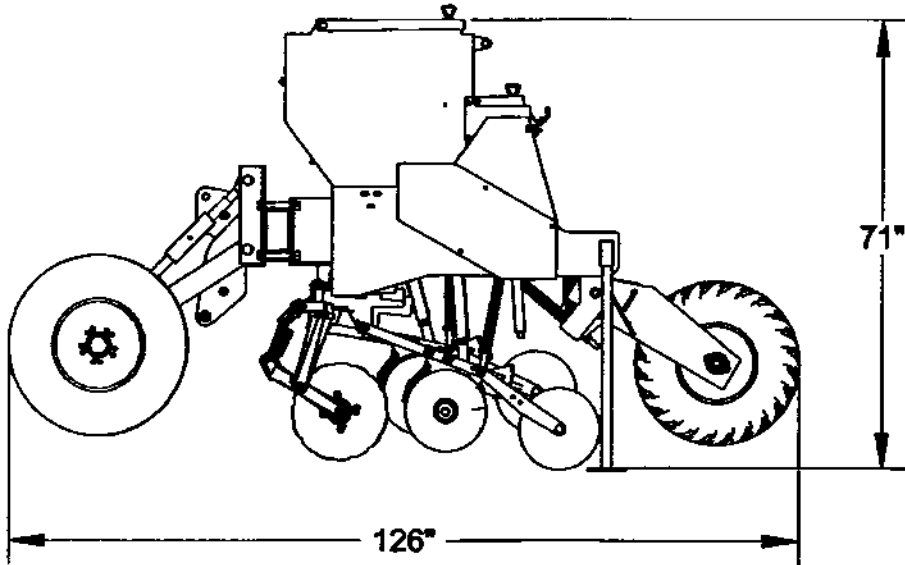

SWRR0038  
3/22/02 JB

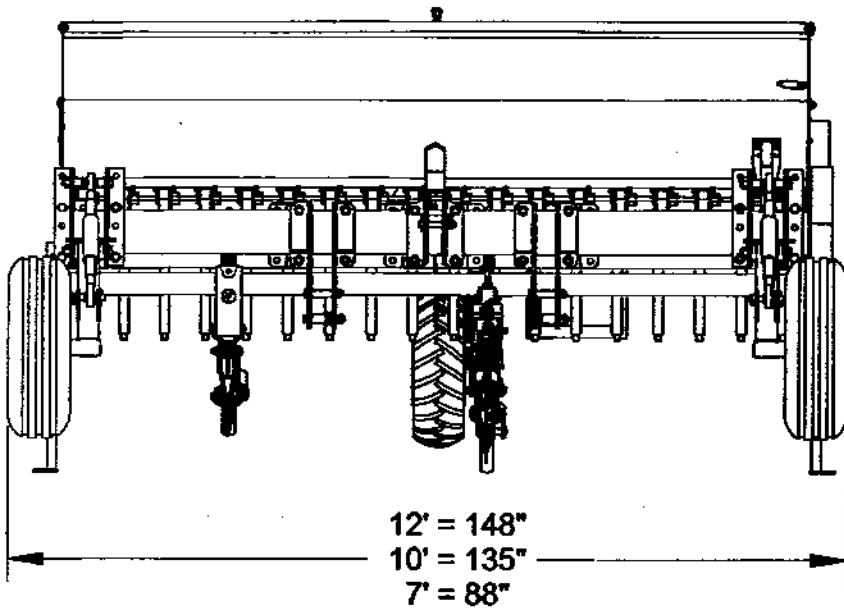

NOTE: 7' HAS NO  
GAUGE WHEELS

# SPECIFICATIONS

## PULL TYPE DRILL

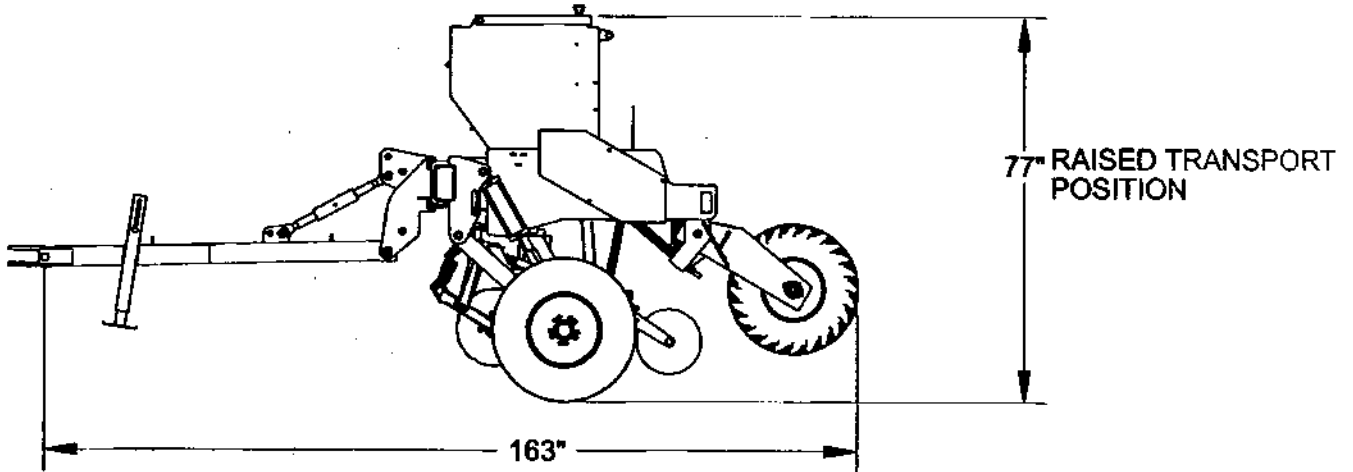

SWRR0037  
3/22/02 JB

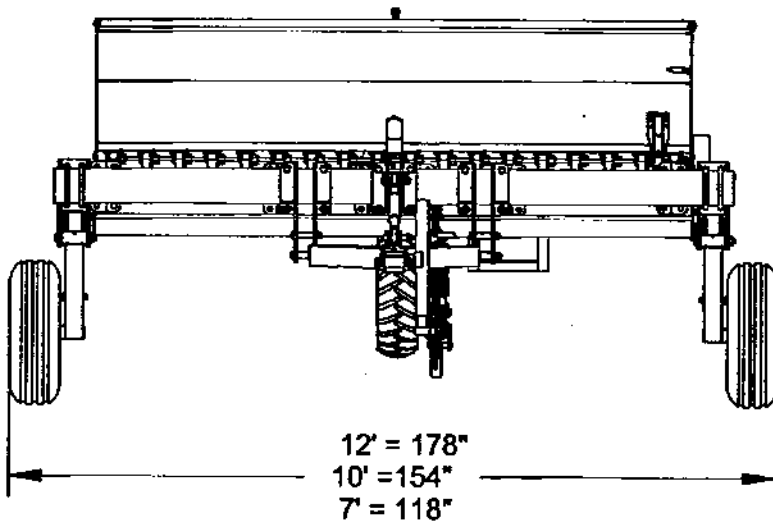

# 2055 & 2100 DRILL PARTS ASSEMBLIES

## HITCH ASSEMBLY

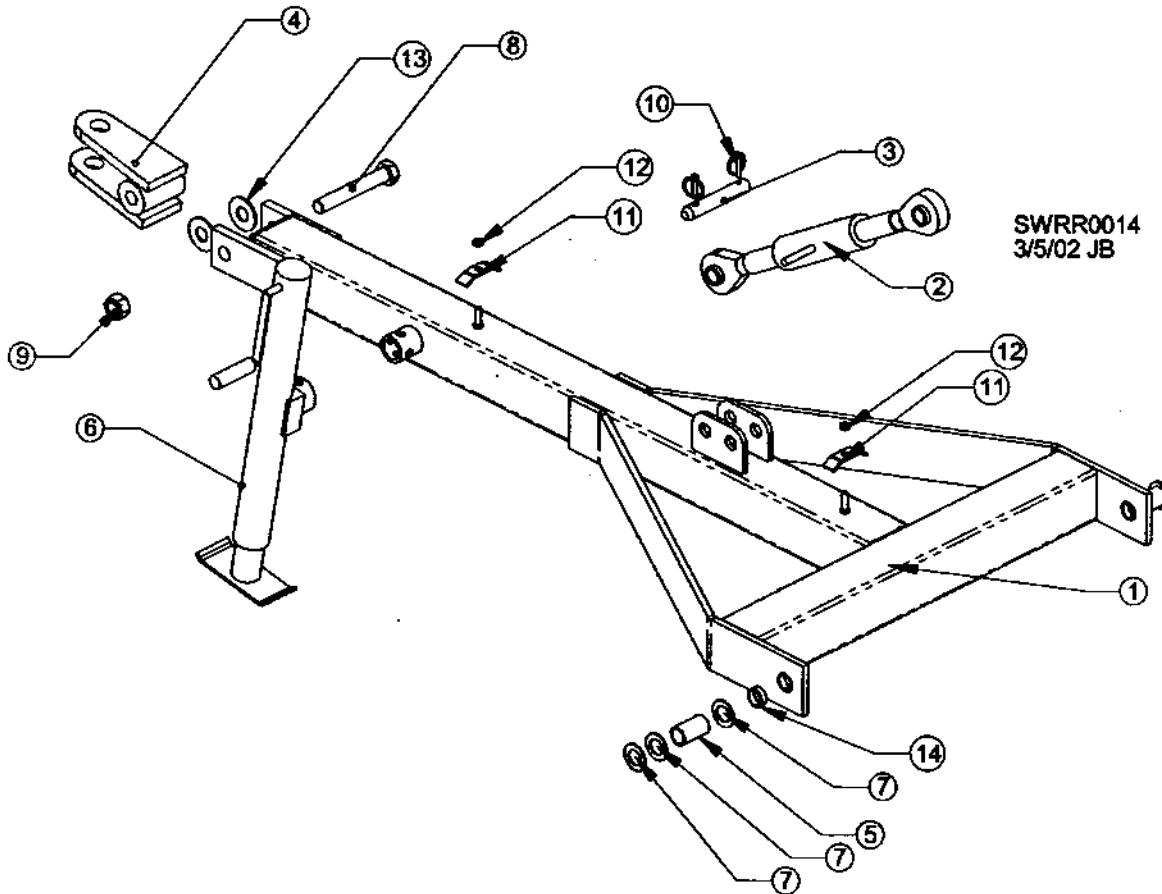

REF. #	DESCRIPTION	QTY	COMP. #
1	Hitch Pull Type Weldment	1	RR1258
2	Turnbuckle TL 1730, 1-1/4" x 20 - 30" Reach	1	J0903
3	Upper 3 PT Pin, Cat II	1	S18456
4	Mount Clevis Hitch Weldment	1	S18151
5	Bushing, 1-3/8OD x 1-1/8ID x 2-3/8"	2	M3318
6	Jack, Side Wind, 2000 lb.	1	J8207
7	Bushing, Machine, 1-1/8, 14 Ga. Regular	6	J1270
8	Screw, 1-8 x 6.5 HHCS PLT. Gr. 5	1	J0917
9	Nut, Top Lock, 1-8	1	J1061
10	Lynch Pin, 7/16"	2	J15481
11	Clamp, Hydraulic Hose (2)	2	R121848
12	Nut, Hex, 3/8-16, PLT, Lock, Gr. A	2	J1025
13	Washer, Flat, 1", PLT	2	J1132
14	Bushing, 1-3/8 x 1-1/8 x 1/2" Split	2	J00849

# FRAME ASSEMBLY 7FT & 10FT & 12FT

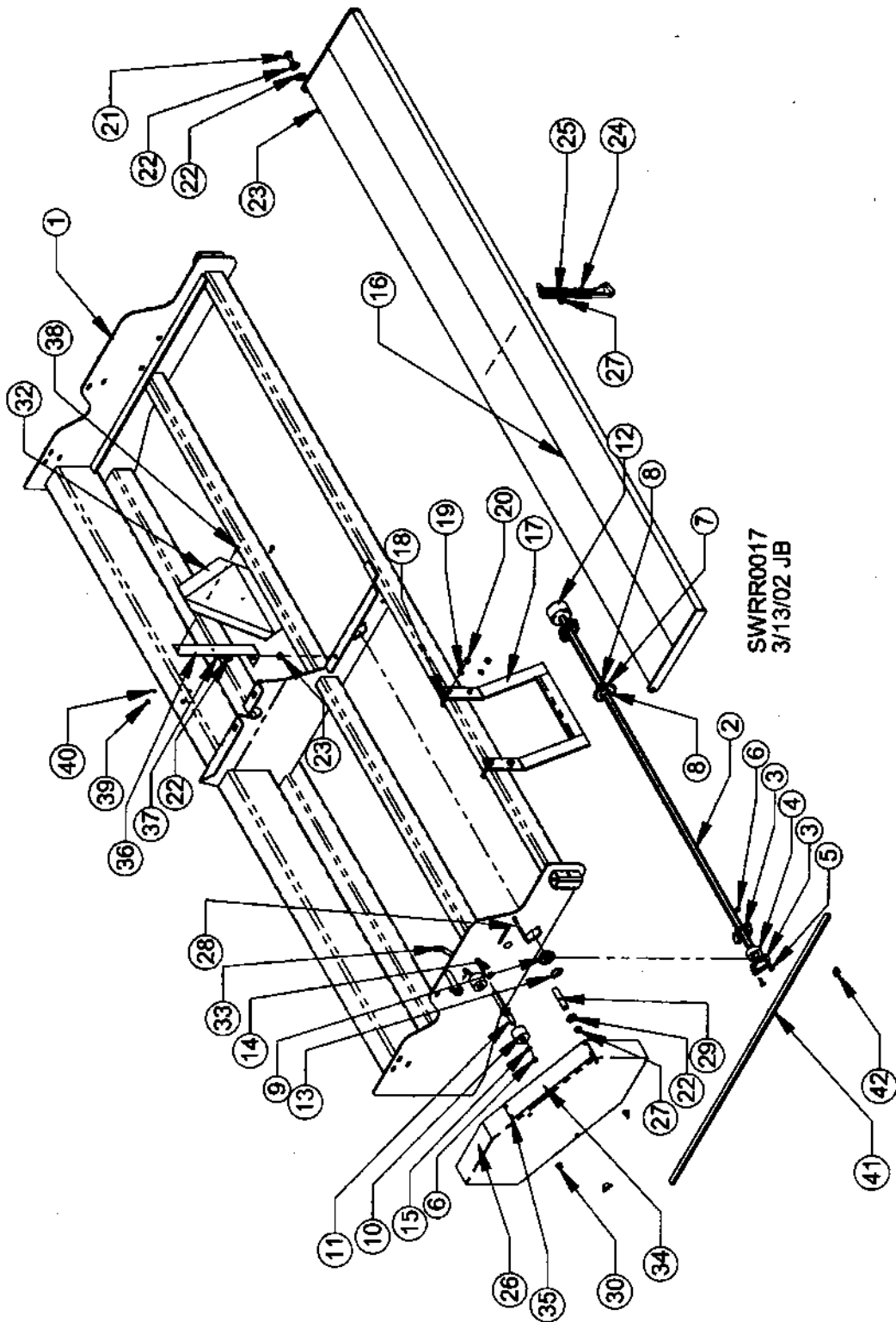

SWRR0017  
3/13/02 JB

# FRAME ASSEMBLY

## 7', 10' & 12'

REF. #	DESCRIPTION	7FT		10FT		12FT	
		QTY	COMP. #	QTY	COMP. #	QTY	COMP. #
1	Weldment, Main Frame	1	RR1329	1	RR1300	1	RR1416
2	Hex Jackshaft	1	RR1274	1	RR1273	1	RR1433
3	Flangette, 2 hole for 205 Bearing	4	J00985	4	J00985	4	J00985
4	Bearing, 1", Center, W/L CLR	2	J0005	2	J0005	2	J0005
5	Bolt, 3/8" x 1" Carriage	4	J06064	4	J06064	4	J06064
6	Nut, Lock, 3/8-16, PLT, Gr. A	6	J1025	6	J1025	6	J1025
7	Sprocket, 40B, 19Tooth, .890 Hex Bore	1	J16481	1	J16481	1	J16481
8	Shaft Collar, 1"	2	J1335	2	J1335	2	J1335
9	Sprocket, 40B13, .890 Hex Bore	1	R6590	1	R6590	1	R6590
10	Roller Chain Tightner	2	R6732	2	R6732	2	R6732
11	Bushing, Plastic Chain Tightner	2	R6733	2	R6733	2	R6733
12	Meter, Acre	1	J8119	1	J81135	1	J81135
13	Lynch Pin, 5/16"	1	J1548	1	J1548	1	J1548
14	Bolt, 3/8" x 2-1/2" Carriage, Gr. 5	2	J0656	2	J0656	2	J0656
15	Washer, Flat, 3/8" PLT	2	J1117	2	J1117	2	J1117
16	Walkboard Weldment	1	RR1231	1	RR1205	1	RR1215
17	Step, Drill 2055	1	RR1301	1	RR1301	1	RR1301
18	U-Bolt, 7/16-14 x 3 x 3	2	J08393	2	J08393	2	J08393
19	Washer, Lock, 7/16", PLT, Split	4	J1210	4	J1210	4	J1210
20	Nut, Hex, 7/16-14, PLT	4	J1035	4	J1035	4	J1035
21	Bolt, 1/2-13, 1.5, PLT, Gr. 5, Carriage	3	J0739	3	J0739	3	J0739
22	Washer, Flat, 1/2"	8	J1125	8	J1125	8	J1125
23	Lock Nut, 1/2-13, PLT, Gr. 8	4	J1042	4	J1042	4	J1042
24	Bracket Slide, Walkway	1	RR1137	1	RR1137	1	RR1137
25	Screw, 1/2-13 x 1.75, Gr. 5, HHCS	2	J0733	2	J0733	2	J0733
26	Drill Chain Shield	1	RR1327	1	RR1327	1	RR1327
27	Nut, Hex, 1/2-13, PLT, Gr. 5	5	J1040	1	J1040	1	J1040
28	Bolt, 3/8" - 16 x 4-1/2" Carriage, Gr. 5	3	J0683	3	J0683	3	J0683
29	Chain Guard Spacer	3	R6734	3	R6734	3	R6734
30	Nut, Wing, 3/8-16 PLT	3	J1022	3	J1022	3	J1022
31	Sprocket, 40B23, .890 Hex Bore, (Not Shown)	1	J16482	1	J16482	1	J16482
32	SMV, Sign	1	J2250	1	J2250	1	J2250
33	Sprocket Holder	1	RR1338	1	RR1338	1	RR1338
34	Shield Cover	1	RR1330	1	RR1330	1	RR1330
35	Rivet, Pop, 3/16 x 3/8, #66	4	J1599	4	J1599	4	J1599
36	SMV Bracket	1	W2247	1	W2247	1	W2247
37	Screw, 1/2-13, 1.25, PLT, Gr. 5, HHCS	1	J0728	1	J0728	1	J0728
38	Screw, 1/4 - 20 x 3/4, PLT, Gr. 5, HHCS	2	J0505	2	J0505	2	J0505
39	Nut, Hex, 1/4-20, PLT	2	J0990	2	J0990	2	J0990
40	Washer, Lock, 1/4", PLT, Split	2	J1195	2	J1195	2	J1195
41	Chain, 107 Links, #40	1	RR1336	1	RR1336	1	RR1336
42	Chain, Link, Connector, #40	1	J1745	1	J1745	1	J1745
43	Sprocket, 40B33, .890 Hex Bore (Not Shown)	1	J16484	1	J16484	1	J16484

# GRAIN TANK ASSEMBLY 7', 10' & 12'

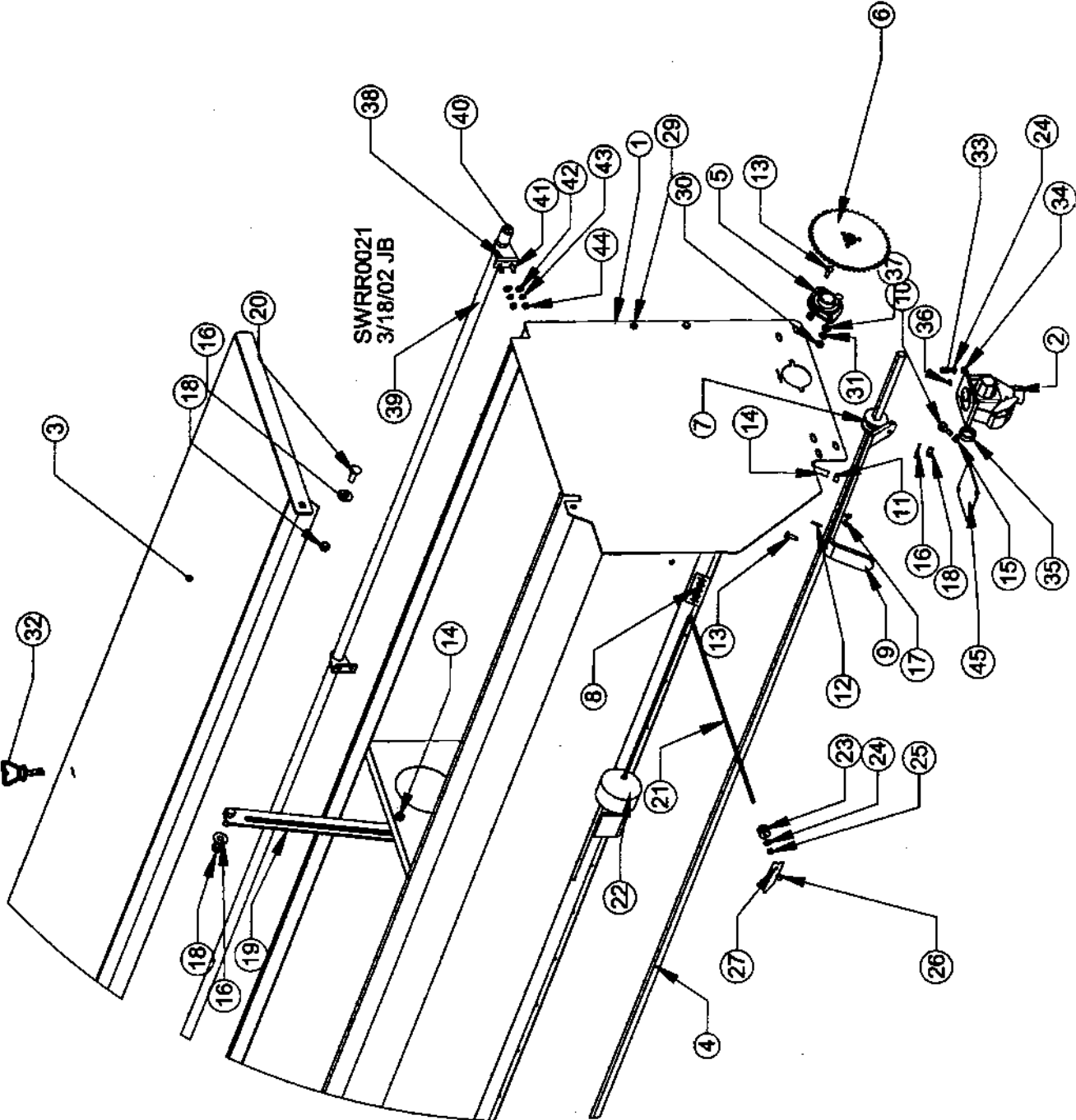

# GRAIN TANK ASSEMBLY

## 7', 10', & 12'

REF. #	DESCRIPTION	7'		10'		12'	
		QTY	COMP. #	QTY	COMP. #	QTY	COMP. #
1	Grain Tank Weldment	1	RR1230	1	RR1210	1	RR1217
2	Meter Housing, Assembly	12	J8120	18	J8120	20	J8120
3	Hopper Lid Weldment	1	RR1232	1	RR1203	1	RR1214
4	Shaft, Meter	1	RR1272	1	RR1207	1	RR1216
5	Bearing, Flange, 1-1/4" W/Flangette	1	J00901	1	J00901	1	J00901
6	Sprocket Drive Weldment	1	R6731	1	R6731	1	R6731
7	Spool, Meter, Adjustment	1	RR1101	1	RR1101	1	RR1101
8	Plate, Gauge, Lever Adjustment 3 to 1	1	L0845	1	L0845	1	L0845
9	Arm, Adjusting	1	RR1104	1	RR1104	1	RR1104
10	Bearing, Cam Follower, .75 CF 3/4S	1	J0035	1	J0035	1	J0035
11	Spacer, Medium Swivel	1	RR1105	1	RR1105	1	RR1105
12	Roll Pin, 5/32, 1 PLT	1	J1480	1	J1480	1	J1480
13	Bolt, 3/8" x 1" Carriage	3	J06064	3	J06064	3	J06064
14	Screw, 1/2-13, 1.5, Gr. 5, HHCS	3	J0730	3	J0730	3	J0730
15	Nut, Hex, 3/8-24, PLT, Fine Threaded	1	J1030	1	J1030	1	J1030
16	Washer, Flat, 1/2"	5	J1125	5	J1125	5	J1125
17	Nut, Wing, 3/8-16, PLT	1	J1022	1	J1022	1	J1022
18	Nut, Lock, 1/2-13, PLT, Gr. 8	5	J1042	5	J1042	5	J1042
19	Bracket, Support, Lid	1	RR1111	1	RR1111	1	RR1111
20	Bolt, Carriage, 1/2-13, 1.5, PLT, Gr. 5,	2	J0739	2	J0739	2	J0739
21	Rod, Indicator	1	RR1208	1	RR1208	1	RR1208
22	Float, Drill Level Indicator	1	J6982	1	J6982	1	J6982
23	Grommet, Rubber, 1/4 x 3/8 x 5/8 Long	1	J49765	1	J49765	1	J49765
24	Washer, Flat, 1/4, PLT	26	J1105	38	J1105	38	J1105
25	Nut, Hex, 1/4-20, PLT	2	J0990	2	J0990	2	J0990
26	Nut, Hex, Acorn, , 1/4-20, PLT	1	J0989	1	J0989	1	J0989
27	Pointer	1	R6603	1	R6603	1	R6603
28	Handle, Grain Hopper	2	RR1209	2	RR1209	2	RR1209
29	Screw, 3/8-16, 1, PLT, Gr. 5, HHCS	4	J0606	4	J0606	4	J0606
30	Nut, Hex, 3/8-16, PLT	6	J1020	6	J1020	6	J1020
31	Washer, Lock, 3/8, PLT, Split	6	J1205	6	J1205	6	J1205
32	Latch, Bail Handle	1	J23010	1	J23010	1	J23010
33	Screw, 1/4-20, 3/4", PLT, Gr. 5, HHCS	24	J0505	36	J0505	36	J0505
34	Nut, Lock, 1/4-20, PLT	24	J0992	36	J0992	36	J0992
35	Collar, Lock, Krause Meter	12	R6565	18	R6565	18	R6565
36	Setscrew, 1/4-20, 1/2", SH	12	J1075	18	J1075	18	J1075
37	Washer, Flat, 3/8, PLT	2	J1117	2	J1117	2	J1117
38	Flange Bracket, Handle flange, Painted	2	RR1277	2	RR1277	2	RR1277
39	Handle Weldment	1	RR1276	1	RR1278	1	RR1278
40	Cap, Rubber, 1"	2	J2232	2	J2232	2	J2232
41	Screw, 5/16-18, 1, PLT, Gr. 5, HHCS	6	J0527	6	J0527	6	J0527
42	Washer, Flat, 5/16", PLT	6	J1111	6	J1111	6	J1111
43	Washer, Lock, 5/16", PLT, Split	6	J1200	6	J1200	6	J1200
44	Nut, Hex, 5/16-18, PLT	6	J1002	6	J1002	6	J1002
45	Plug, Meter, Hopper Bottom	2	RR1122	2	RR1122	2	RR1122



# REAR DRIVE WHEEL ASSEMBLY

SWRR0012  
2/11/02 JB

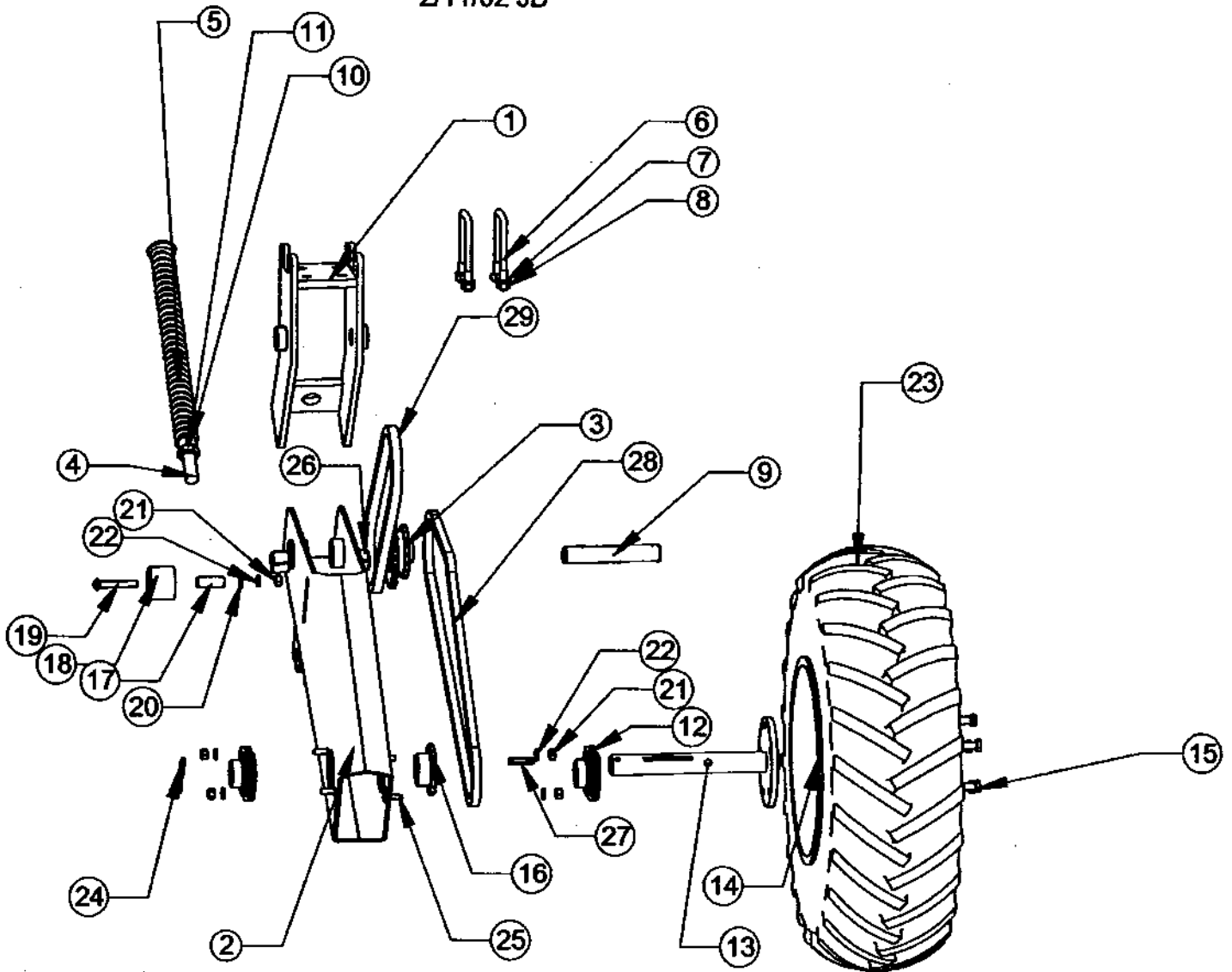

# REAR DRIVE WHEEL ASSEMBLY

REF. #	DESCRIPTION	QTY	COMP. #
1	Drive Wheel Bracket Weldment	1	RR1253
2	Body, Drive Wheel Weldment	1	RR1254
3	Pivot Sprocket Assembly	1	RR1256
4	Rod, Spring, Weldment	1	RR1257
5	Spring, Comp. .80 # 1.585 OD x 15"	1	J23662
6	U-Bolt, 7/16-14 x 2 x 4-1/4"	2	J0839
7	Washer, Lock, 7/16, PLT, Split	4	J1210
8	Nut, Hex, 7/16-14, PLT	4	J1035
9	Pin, Drive Wheel	1	RR1114
10	Nut, Hex 3/4-10, PLT, Gr. 5	1	J1051
11	Nut, Hex, 3/4 - Jam PLT	1	J1058
12	Bearing, W/Flanges, 1-1/4"	2	J00901
13	Drive Axle Weldment	1	RR1115
14	Rim, 12" x 7", 5 on 4-1/2"	1	J7244
15	Lug Bolt, 7/16-20, NF x 1	5	J0712
16	Sprocket, 40B16, 1.25 Bore, Keyway	1	J1640
17	Bushing, Plastic Chain Tightner	1	R6733
18	Roller Chain Tightner	1	R6732
19	Bolt, Carriage 3/8" x 2-1/2", 3/8 - 16, 2.5, Gr. 5	1	J0656
20	Washer, Flat, 3/8", PLT	2	J1117
21	Nut, Hex, 3/8-16, PLT	5	J1020
22	Washer, Lock, 3/8, PLT, Split	5	J1205
23	Tire, Super Lug, 23 x 8-1/2" x 12 Only	1	J7243
24	Pin, Cotter, 1/4", 2 PLT	1	J1455
25	Bolt, 3/8" x 1", Carriage	4	J06064
26	Bushing, 1-1/4 x 1 x 1", Split	2	J00846
27	Key, 1/4 x 1-1/2"	1	E9007
28	Chain, Roller, #40 111 Links	1	RR1443
29	Chain, #40, 66 Links	1	RR1337
30	Chain Connector, Link, #40 (Not Shown)	1	J1745

# TOOL BAR - PULL TYPE

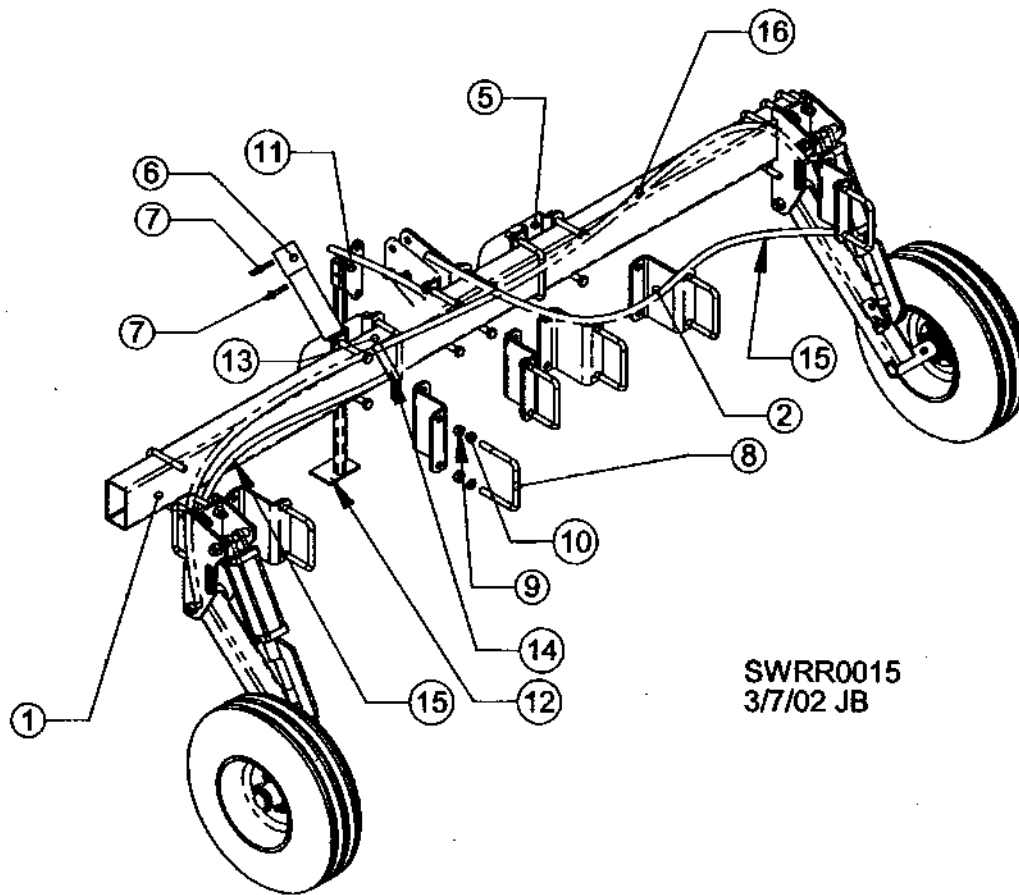

SWRR0015  
3/7/02 JB

REF. #	DESCRIPTION	7FT		10FT		12FT	
		QTY	COMP. #	QTY	COMP.#	QTY	COMP. #
1	Extension Bar	1	RR1266	1	RR1264	1	RR1418
2	Spacer	4	RR1243	6	RR1243	8	RR1243
5	3-Point Assembly	1	RR1252	1	RR1252	1	RR1252
6	Holder Manual	1	J73620	1	J73620	1	J73620
7	Clamp, Hose, 1-5/8 - 3-1/2	2	J23211	1	J23211	1	J23211
8	U-Bolt, 7/8 - 9 x 7 x 5-1/2"	8	J08373	8	J08373	12	J08373
9	Hex Nut, 7/8"	12	J1059	12	J1059	24	J1059
10	Washer, Lock, 7/8"	12	J1222	12	J1222	24	J1222
11	Shipping Stand	1	R1331	1	R1331	1	R1331
12	Stand, Parking, Weldment	1	R6604	1	R6604	1	R6604
13	Pin, Snapper	1	J5431	1	J5431	1	J5431
14	Bracket, Tube Holder	1	RR1333	1	RR1333	1	RR1333
15	Hydraulic hose, Long	2	RR1465	2	RR1467	2	RR1469
16	Hydraulic hose, Short	1	RR1466	1	RR1468	1	RR1470

# TOOL BAR - 3-POINT

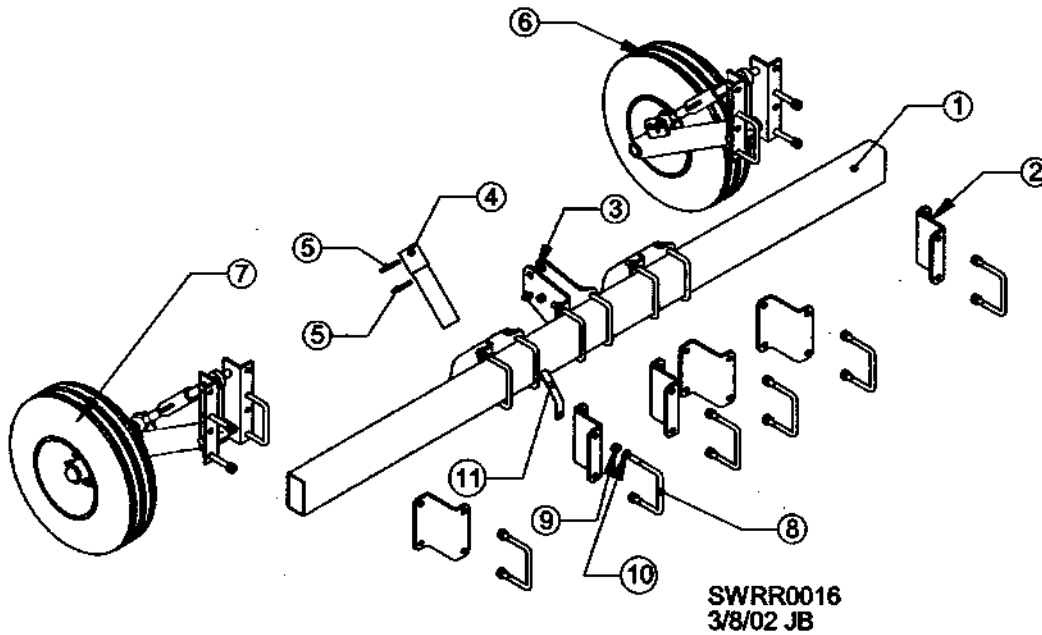

REF. #	DESCRIPTION	7FT		10FT		12FT	
		QTY	COMP. #	QTY	COMP. #	QTY	COMP. #
1	Extension Bar	1	RR1267	1	RR1265	1	RR1418
2	Spacer, Toolbar	4	RR1243	6	RR1243	8	RR1243
3	Hitch, 3-Point Assembly	1	RR1252	1	RR1252	1	RR1252
4	Holder, Manual	1	J73620	1	J73620	1	J73620
5	Clamp, Hose, 1-5/8 - 3-1/2", dia.	2	J2311	2	J23211	2	J23211
6	Gauge Wheel Assembly, Right	----	----	1	RR1262	1	RR1262
7	Gauge Wheel Assembly, Left	----	----	1	RR1263	1	RR1263
8	U-Bolt, 7/8 - 9 x 7 x 6-1/2	4	J08373	6	J08373	8	J08373
9	Nut, Hex, 7/8"-9, PLT	8	J1059	12	J1059	16	J1059
10	Washer, Lock, 7/8", PLT, Split	8	J1222	12	J1222	16	J1222
11	Bracket, Tube Holder	1	RR1333	1	RR1333	1	RR1333

# LIFT WHEEL ASSEMBLY PULL TYPE DRILL

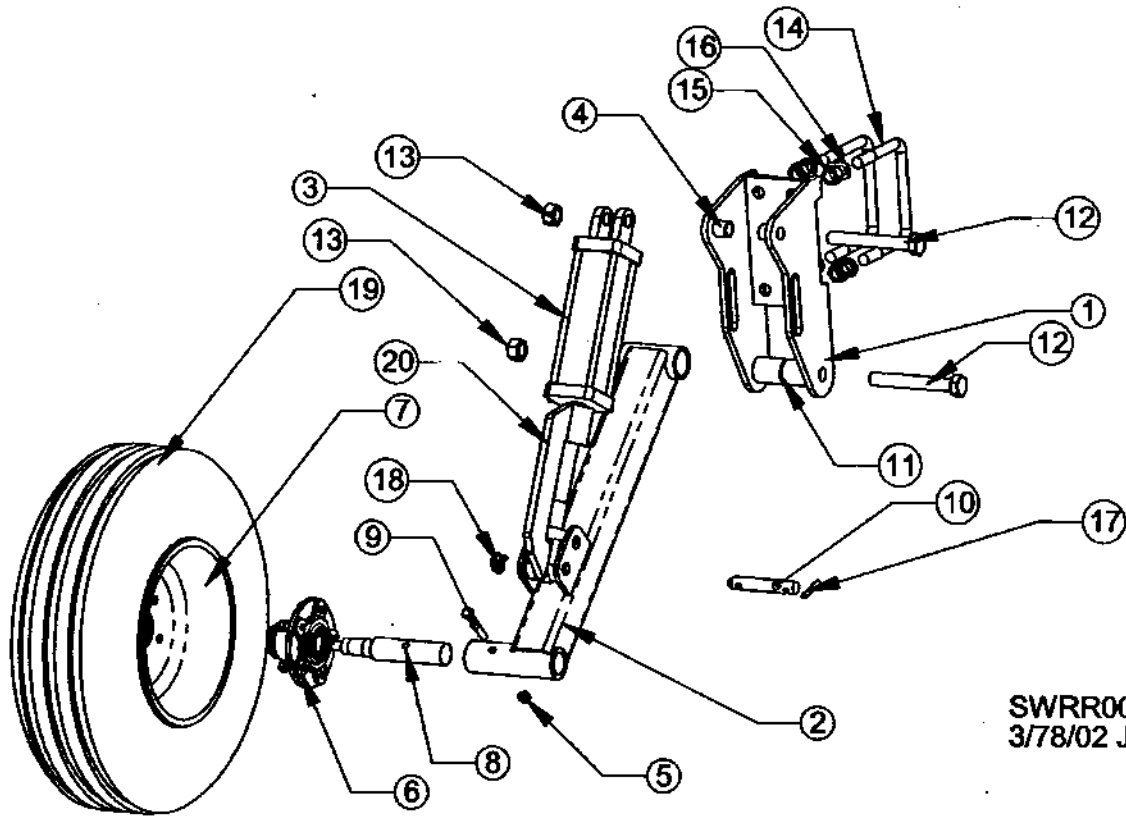

SWRR0018  
3/78/02 JB

REF. #	DESCRIPTION	7FT		10&12FT	
		QTY	COMP. #	QTY	COMP. #
1	Wheel Support Weldment	1	RR1241	1	RR1241
2	Arm Lift Wheel Weldment, Right	1	RR1249	1	RR1249
2	Arm Lift Wheel Weldment, Left	1	RR1242	1	RR1242
3	Cylinder, Right Hand (2-1/2" - 7") (2-3/4" 10')	1	J7174	1	J71941
3	Cylinder, Left Hand (2-3/4" - 7") (3" - 10')	1	J7193	1	J71931
4	Spacer, 1-1/8"	2	M5112	2	M5112
5	Nut, Lock, 1/2-13, PLT, Gr. 8	1	J1042	1	J1042
6	Hub Assembly Complete, 5 Bolt (7Ft) Left & Right	1	J7280	---	---
6	Hub Assembly Complete, 6 Bolt (10Ft) Left & Right	---	---	1	J72352
7	Rim, Wheel, 15 x 5, 5 Bolt (7Ft) Left & Right	1	J72775	---	---
7	Rim, Wheel, 15 x 8, 6 Bolt (10Ft) Left & Right	---	---	1	J72783
8	Spindle, 5 Bolt, (7Ft) Left & Right	1	S15394	---	---
8	Spindle, 6 Bolt, (10Ft) Left & Right	---	---	1	R305004
9	Screw, 1/2-13, 3.25, PLT, Gr. 5 HHCS	1	J0752	1	J0752
10	Pin, Upper, 3PT, Cat II	1	S18456	1	S18456
11	Bushing, Pivot, Gauge Wheel	1	W20527	1	W20527
12	Screw, 1-8 x 7.5, HHCS, PLT, Gr. 5	2	J0918	2	J0918
13	Nut, Top Lock, 1-8	2	J1061	2	J1061
14	U-Bolt, 7/8-9 x 7 x 6/1/2"	2	J08373	2	J08373
15	Nut, Hex, 7/8-9, PLT	4	J1059	4	J1059
16	Washer, Lock, 7/8"	4	J1222	4	J1222
17	Pin, Roll, 3/8" x 2-1/2"	1	J1513	1	J1513
18	Lynch Pin, 7/16"	1	J15481	1	J15481
19	Tire, Tube Type, 9.5L-15, 6-Ply	1	J72545	1	J72545
20	Lock, Transport, Weldment	1	RR1275	1	RR1275

# GAUGE WHEEL ASSEMBLY - 3 POINT DRILL

3/8/02 JB

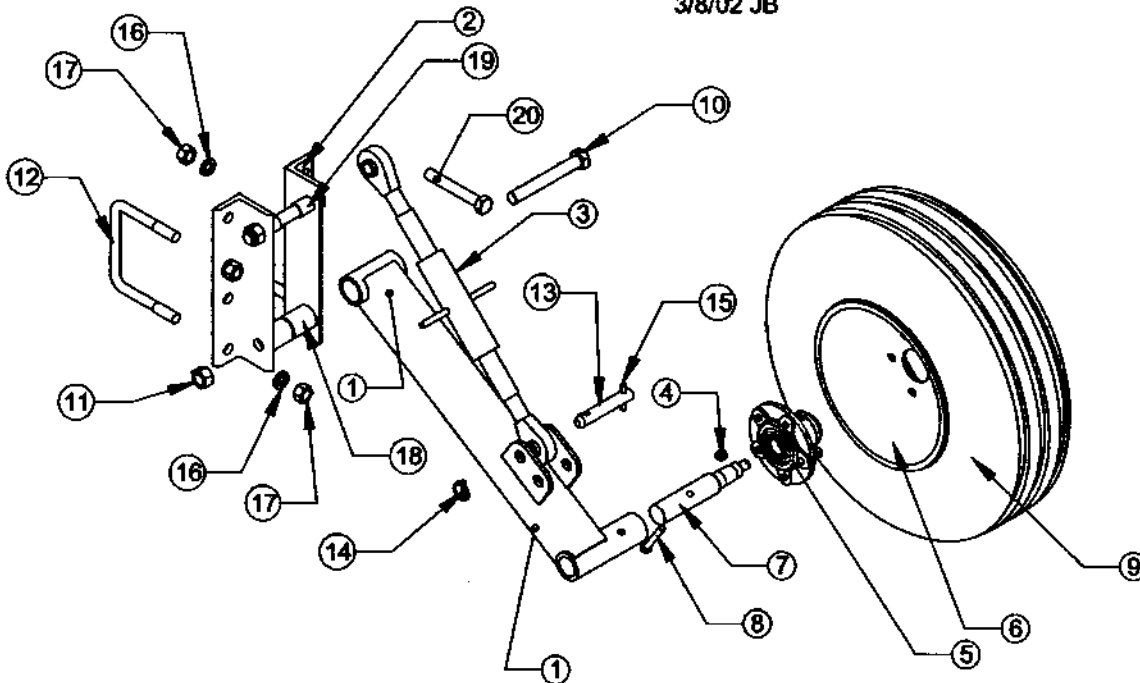

10FT & 12FT

REF. #	DESCRIPTION	QTY	COMP. #
1	Arm Lift Wheel Right	1	RR1249
1	Arm Lift Wheel Left	1	RR1242
2	Angle Mounting, Gauge Wheel	2	RR1244
3	Turnbuckle - 1-1/8", NCX21-31	1	J0905
4	Nut, Lock, 1/2-13, PLT, Gr. 8	1	J1042
5	Hub assembly, 6 Bolt, 3000 # W/Accs.	1	J72352
6	Rim, 6hole, 8 x 15, 4-5/8, Pilot	1	J72783
7	Spindle, 6 Bolt, 3000#, 1.75" x 12"	1	R305004
8	Screw, 1/2-13, 3.25	1	J0752
9	Tire, 9.5LX15, 6 Ply W/Tube	1	J72545
10	Screw, 1-8 x 7.5, HHCS, Gr. 5, PLT	2	J0918
11	Nut, Top Lock, 1-8	2	J1061
12	U-Bolt, 7/8-9 x 7 x 6-1/2"	1	J08373
13	Upper, 3 Point, Cat II	1	S18456
14	Lynch Pin, 7/16"	1	J15481
15	Roll Pin, 3/8 x 2-1/2	1	J1513
16	Washer, Lock, 7/8, PLT, Split	4	J1222
17	Nut, Hex, 7/8-9, PLT	4	J1059
18	Bushing, Pivot, Gauge Wheel	1	W20527
19	Spacer, 1.25OD x 1.03ID s 1.475	2	M5112
20	Screw, 7/8-9 x 6, HHCS, Gr. 5	2	J0836

## 3 POINT HITCH FITS NO-TILL (With Front Bar)

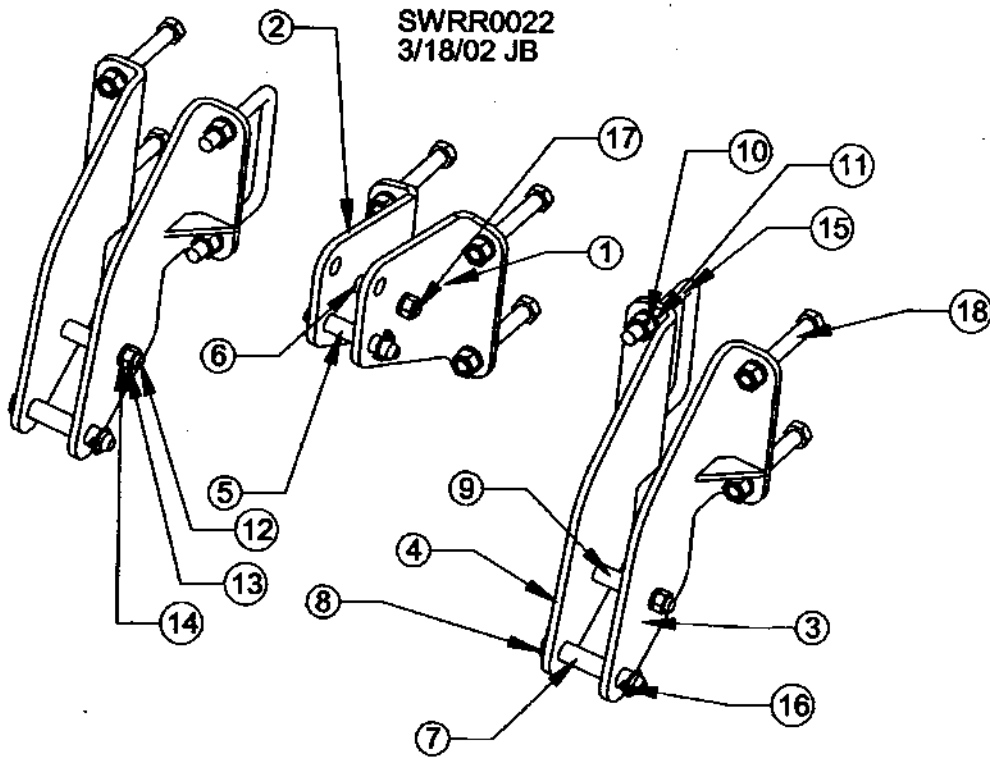

REF. #	DESCRIPTION	QTY	COMP. #
1	Center Mast Plate, Left	1	RR1247
2	Center Mast Plate, Right	1	RR1248
3	Left Lower Arm Weldment	2	RR1245
4	Right Lower Arm Weldment	2	RR1246
5	Upper 3 PT Pin, 1-1/8 x 4-3/4 x 6-1/2" Long	1	S18456
6	Bushing, 3/4ID, Sch40, 2-1/2" Long	1	RR1250
7	Lower Pin, 1-1/8 x 4-3/4 x 6-1/2 Long	2	J15387
8	Roll Pin, 3/8 x 2-1/2"	3	J1513
9	Bushing, 3/4ID, Sch40, 3-3/8 Long	2	RR1251
10	Nut, Hex, 7/8-9 PLT	12	J1059
11	Washer, Lock, 7/8"-9, PLT	12	J1222
12	Screw, 3/4-10 x 5-1/2" PLT, Gr. 5	2	J0813
13	Nut, Hex, 3/4-10, PLT, Gr. 5	3	J1051
14	Washer, Lock, 3/4", PLT, Split	3	J1220
15	U-Bolt, 7/8 - 9 x 7 x 6-1/2"	2	J08373
16	Lynch Pin, 7/16"	3	J15481
17	Screw, 3/4 - 10 x 4.5 HHCS, PLT, Gr. 5	1	J0817
18	Bolt, 7/8 - 9 x 6.5, Gr. 5	8	J08361

# 3-POINT HITCH FITS CONVENTIONAL

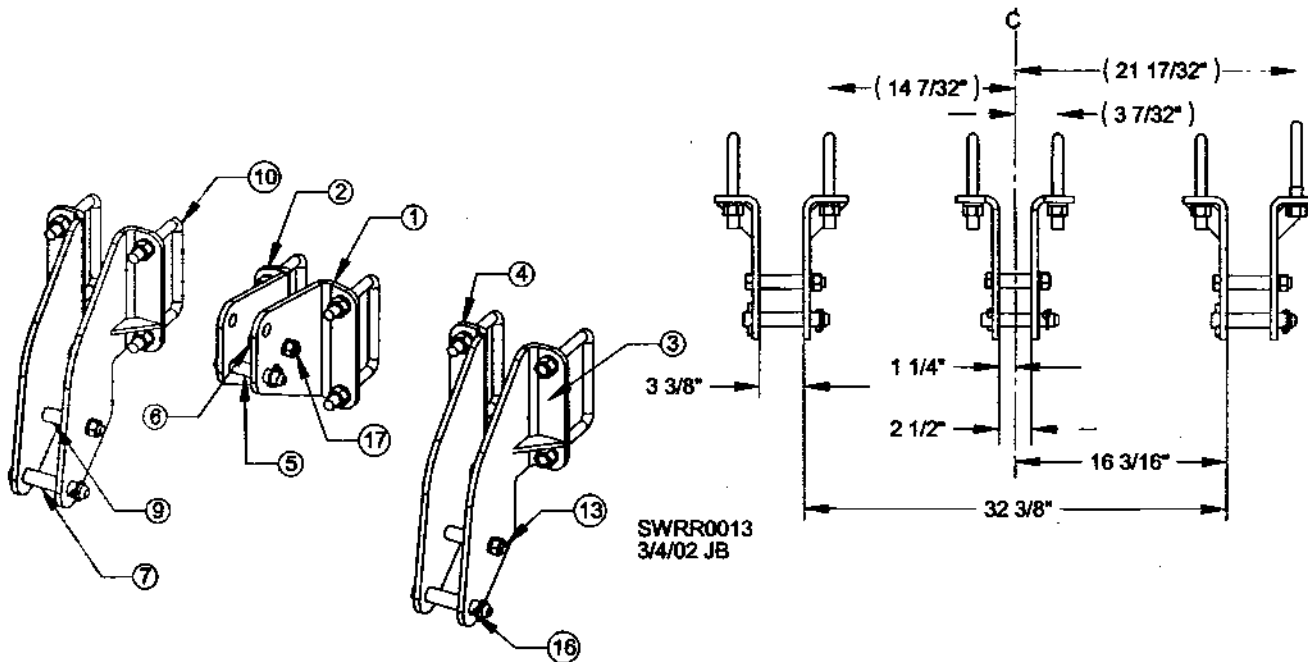

REF. #	DESCRIPTION	QTY	COMP. #
1	Plate, Center Mast, Left	1	RR1247
2	Plate, Center Mast, Right	1	RR1248
3	Lower Arm Weldment, Left	2	RR1245
4	Lower Arm Weldment, Right	2	RR1246
5	Pin, Upper 3PT, Cat II	1	S18456
6	Bushing, 3/4ID, Sch40, 20 1/2" Long	1	RR1250
7	Pin, Lower, 1-1/8 x 4-3/4 x 6, Long	2	J15387
8	Pin, Roll, 3/8 x 2-1/2"	3	J1513
9	Bushing, 3/4ID, Sch40, 3-3/8 Long	2	RR1251
10	U-Bolt, 7/8-9 x 7 x 6-1/2	6	J08373
11	Nut, Hex, 7/8 - 9 PLT	12	J1059
12	Washer, Lock, 7/8", PLT, Split	12	J1222
13	Screw, 3/4-10 x 5-1/2, PLT, Gr. 5 HHCS	2	J0813
14	Nut, Hex, 3/4 - 10, PLT, Gr. 5	3	J1051
15	Washer, Lock, 3/4", PLT, Split	3	J1220
16	Lynch Pin, 7/16"	3	J15481
17	Screw, 3/4- 10 x 4.5 HHCS, PLT, Gr. 5	1	J0817



# OPENER ASSEMBLY RR5081 2055 OPENER

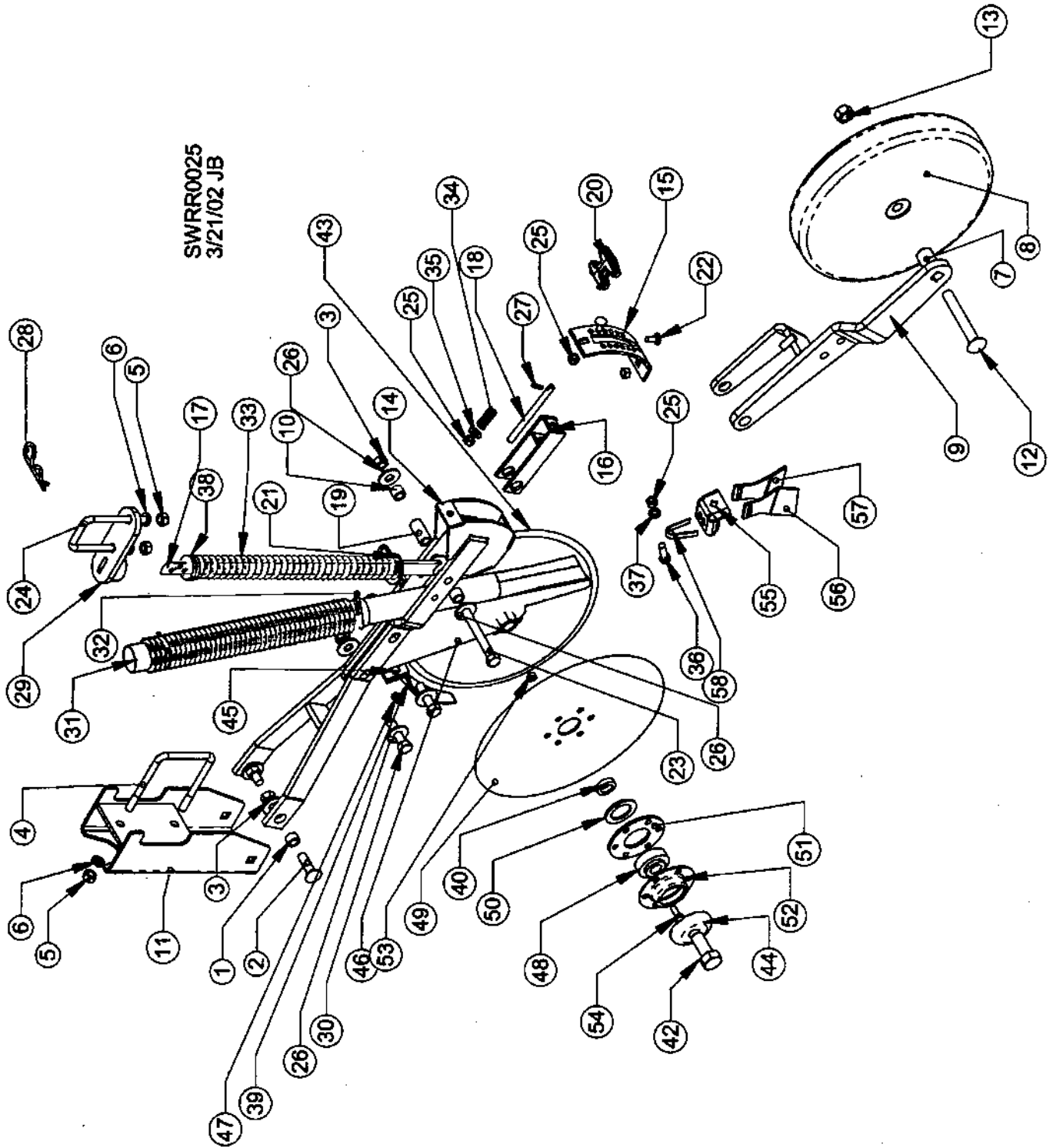

# OPENER ASSEMBLY RR5081

## 2055 Opener

REF. #	DESCRIPTION	QTY	COMP. #
1	Bushing, 3/4OD x 11Ga. X 15/32 Long	2	R103002
2	Bolt, 1/2 - 13, 1.75, PLT, Gr.5, Carriage	2	J0731
3	Nut, Lock, 1/2 - 13, PLT, Gr. 8	5	J1042
4	U-Bolt, 7/16 - 14 x 3-1/2" x 4-1/2"	4	J08394
5	Nut, Hex, 7/16, PLT	4	J1035
6	Washer, Lock, 7/16, PLT, Split	1	J1210
7	Bushing, Wheel Spacer, 230 Opener	1	M2207
8	Wheel, Assembly, 2 x 13, Nylon, Rim	1	J72661
9	Single Arm Press Wheel Weldment	2	RR1326
10	Bushing 3/4OD x 11Ga. X 9/16 long	1	R103077
11	Row Mounting Bracket, Weldment	1	RR1325
12	Bolt, 5/8 - 11, 4.5, PLT, Gr. 5, Carriage	1	J07846
13	Nut, Top Lock, 5/8 - 11	1	J1047
14	Frame, Opener, 2050	1	R6551
15	Plate, Depth Adjustment	1	R6550
16	Receiver, T-Handle	1	R6553
17	Rod, Spring, Down Pressure	1	R6554
18	Rod, T-Handle, Opener	1	R6555
19	Bushing, Frame, Opener	1	R6557
20	T-Handle Opener, 2050	1	R6577
21	Seat, Spring, Unit, Disc Opener	1	R120029
22	Bolt, Carriage, 3/8-16, 3/4, PLT, Gr. 5	2	J0609
23	Screw, 1/2 - 13, 4-1/2, Gr. 5, HHCS	1	J0758
24	U-Bolt, 7/16 - 14 x 2 x 4-1/4	1	J0839
25	Nut, Hex, 3/8 - 16, PLT Lock	4	J1025
26	Washer, Flat, 1/2"	8	J1125
27	Pin, Roll, 3/16, 3/4, PLT	1	J1530
28	Clip, Hair Pin, .09 x 2	2	J5414
29	Down Pressure Spring Bracket	1	RR1306
30	Screw, 1/2 - 13, 2", PLT, Gr. 5 HHCS	2	J0737
31	Tube, Seed, Rubber	1	J7360
32	Clamp, Seed Tube	2	J7361
33	Spring, Complete, 1-1/16ID, 15 Long	1	J23662
34	Spring, Complete, .120WR, 7 Coils	1	J2381
35	Washer, Flat, 3/8, PLT	1	J1117
36	Screw, 3/8 - 16, 1.25", PLT	1	J0616
37	Washer, Lock, 3/8, PLT	1	J1205
38	Plastic Bushing for Top of Spring	2	R9999
39	Blade Guard for DDO	1	R520384
40	Bearing Spacer, 1-1/4OD, .765ID, .300	2	R305002
41	Screw, 3/4 - 10, 1.75, PLT, Gr. 5, HHCS	1	J08063
42	Screw, 3/4 - 10, 1.75, PLT, Gr. 5, LH	1	J08065
43	Bearing & Blade Assembly, 13", DDO	1	R522045
44	Dust Shield, DDO Coultter	2	R124023
45	Bolt, 1/4 - 20 x 3/4	2	J0505
46	Opener, Unit	1	R520001
47	Nut, Lock, 1/4 - 20, PLT	2	J0992
48	Bearing, DDO, Coultter	1	J0054
49	Blade, Disc, 13"	1	K5577
50	Bushing, Machine, 1-3/8 - 10 Ga. N. Rim	1	J1275
51	Plate, Bearing, D/O 1980	1	R105009
52	Housing, Bearing, DDO, 1 x 10 Wheel	1	J0064
53	Nut, Lock, 5/16 - 18, PLT	1	J1010
54	Screw, 5/16 - 18, 3/4" PLT	1	J0520
55	Bracket, Scrapper, Mounting	1	R322004
56	Scraper, Inside, LH	1	R120272
57	Scraper, Inside, RH	1	R120271
58	Spring, Scrapers	1	R720010

**CONVENTIONAL OPENER ASSEMBLY**  
**RR1420**  
**2100 OPENER**

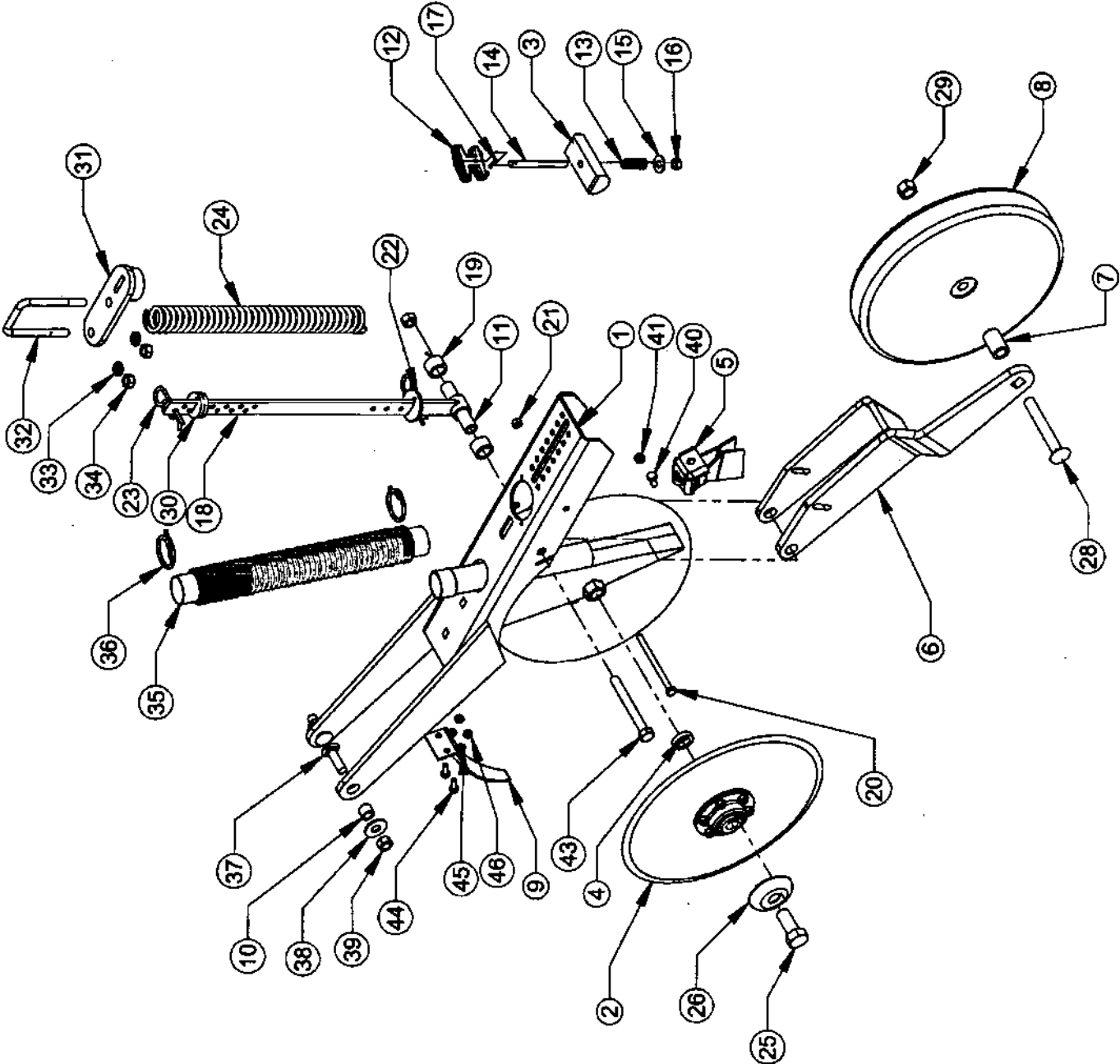

**CONVENTIONAL OPENER ASSEMBLY**  
**RR1420**  
**2100 OPENER**

REF. #	DESCRIPTION	QTY	COMP. #
1	Weldment, Opener Frame	1	RR1343
2	Assembly, Bearing & Blade 13" DDO	2	R522045
3	Depth Adjustment Block	1	RR1345
4	Bearing Spacer, 1-1/4"OD, .765ID, .300	2	R305002
5	Assembly, Inside Scrapper	1	R522876
6	Single side Press Wheel	1	RR1344
7	Bushing 1 x .625 x 1.5	1	M2207
8	Wheel, 2 x 13, Assembly, Nylon, Ace	1	J72661
9	Blade Guard	1	R520384
10	Spacer, Swivel	2	R103002
11	Bushing	1	RR1347
12	T-Handle, Opener	1	R6577
13	Spring, Comp., 120WR, 7 Coils	1	J2381
14	Rod, T-Handle	1	RR1349
15	Washer, Flat, 3/8, PLT	1	J1117
16	Nut, Hex, 3/8-16, PLT Lock	1	J1025
17	Pin, Roll, 3/16, 3/4", PLT	1	J1530
18	Rod, Spring, Down Pressure	1	R6554
19	Bushing, Down Pressure Rod	2	RR1364
20	Screw, 5/16-18, 4.5, PLT, Gr. 5	1	J0599
21	Nut, Lock, 5/16-18, PLT	1	J1010
22	Seat, Spring, Unit, 2", PLT	1	R120029
23	Clip, Hair Pin, .09 x2	2	J5414
24	Spring, Comp, #80, 1.585OD x 15"	1	J23662
25	Screw, 3/4-10, 1.75, PLT, Gr. 5, LH	1	J08065
26	Dust Shield	2	R124023
27	Screw, 3/4-10, 1.75, PLT, Gr. 5, HHCS	1	J08063
28	Bolt, 5/8-11, 4.5, PLT, Gr. 5, Carriage	1	J07846
29	Nut, 5/8-11, Top Lock	1	J1047
30	Plastic Bushing for Top of Spring	2	R9999
31	Down Pressure Spring Bracket	1	RR1306
32	U-Bolt, 7/16-14 x 2 x 4-1/4"	1	J0839
33	Washer, Lock, 7/16, PLT, Split	2	J1210
34	Nut, Hex, 7/16-14, PLT	2	J1035
35	Seed Tube	1	J7360
36	Clamp Seed Tube	2	J7361
37	Bolt, 1/2-13, 1.75, PLT, Gr. 5, Carriage	2	J0731
38	Washer, Flat, 1/2"	2	J1125
39	Lock Nut, 1/2-13	3	J1042
40	Screw, 5/16-18, PLT	1	J0520
41	Nut, Hex, 5/16, PLT, split	1	J1002
42	Washer, Lock, 5/16, PLT, Split	1	J1200
43	Screw, 1/2-13, 4-1/2, Gr. 5 HHCS	1	J0758
44	Bolt, 1/4-20 x 3/4	2	J0505
45	Washer, Lock, 1/4, PLT	2	J1195
46	Nut, Hex, 1/4-20	2	J0990

# NO TILL RIPPLE COULTER 15"

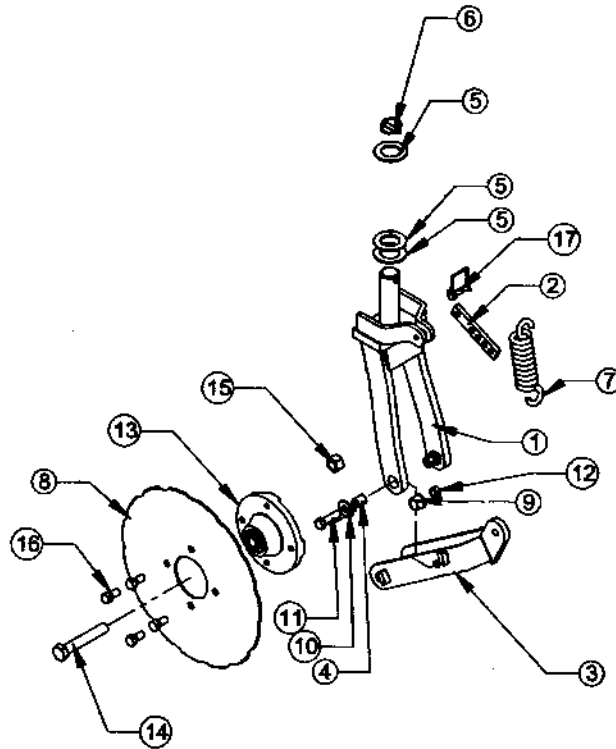

SWRR0049  
10/25/02 JB

REF. #	DESCRIPTION	QTY	COMP. #
1	Coultter Fork Assembly	1	R520192
2	Adjustment Strap, Coultter Spring	1	R120285
3	Coultter Yoke	1	R520195
4	Bushing, Swivel, Large	2	R103003
5	Bushing, Machine, 1-1/2"-10Ga., N-Rim	3	J1285
6	Lynch Pin, 7/16"	1	J15481
7	Spring, 2" ID, 10 Coil, 9", 3/8" Wire	1	J2382
8	15" Fluted Coultter Blade	1	K5624
9	Bushing, Oilite Brass	2	J00821
10	Washer, flat, 1/2"	2	J1125
11	Screw, 1/2-13 x 1.75 PLT, Gr. 5 HHCS	2	J0733
12	Lock Nut, 1/2-13	2	J1042
13	Sealed No-Till CLTR Hub	1	RR1367
14	Screw, 3/4-10 x 4.5 PLT, HHCS	1	J0817
15	Nut, Lock, 3/4 - 10, Gr. B	1	J1057
16	Lug Bolt, 1/2 - 20 x 1	4	J07231
17	Pin, Snapper	1	J5430

## NO TILL HUB ASSEMBLY 2100 DRILL

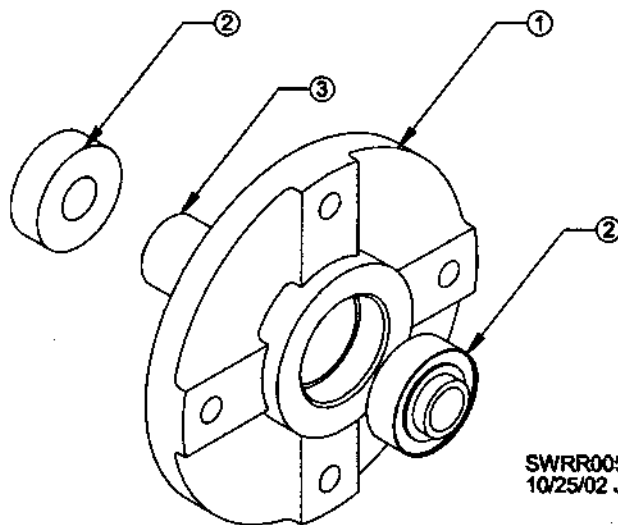

SWRR0050  
10/25/02 JB

REF. #	DESCRIPTION	QTY	COMP. #
1	Coultter Hub Assembly/Sealed , 4 Bolt	1	RR1367
2	Bearing, 3/4", FAFNIR RA012RR	2	J00303
3	Spacer	1	RR1368

## TAPERED BEARING HUB 2055 AND OLDER DRILLS

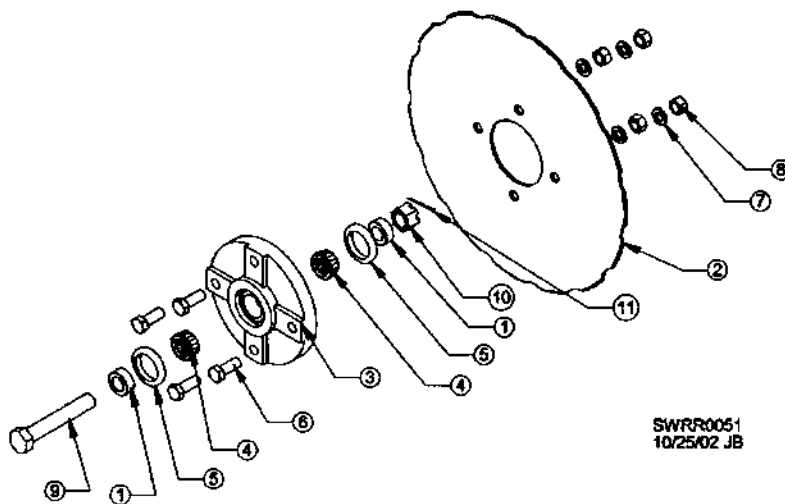

SWRR0051  
10/25/02 JB

REF. #	DESCRIPTION	QTY	COMP. #
1	Spacer, Bearing, FCH	2	R103070
2	Fluted Coultter Blade, 15"	1	K5624
3	Hub, Coultter, Opener, No-Till 4-Bolt	1	R522042
4	Bearing, Roller Taper, Small, LM11949	2	J0127
5	Seal, 2" OD 1-1/4ID, CR#12481	2	J7023
6	Screw, 1/2-13, 1.25, PLT	4	J0728
7	Washer, Lock, 1/2", PLT	4	J1215
8	Lock Nut, 1/2-13	4	J1042
9	Bolt, Spindle	1	R105012
10	Nut, Hex, 3/4-16, Slotted	1	J1050
11	Pin, Cotter, 1/8, 1-1/2, PLT	1	J1421
12	Hitch Weldment, No-till, Short, 2000	1	R520193

## COMPLETE SCRAPER ASSEMBLY - R522168

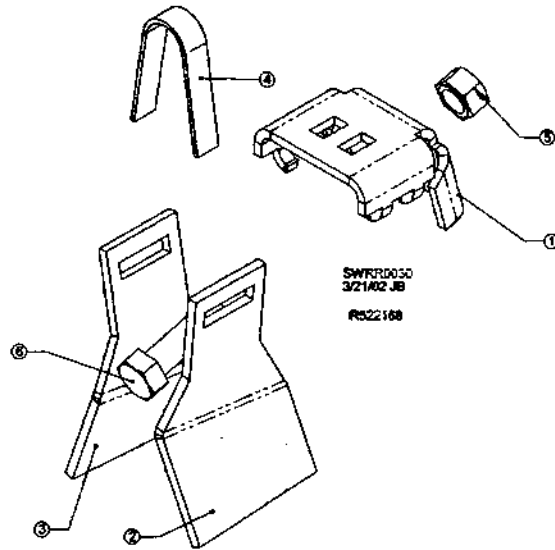

REF. #	DESCRIPTION	QTY	COMP. #
1	Bracket, Scraper Mounting	1	J2384
2	Scraper, Inside, Left - 215 Opener	1	R120272
3	Scraper, Inside, Right - 215 Opener	1	R120271
4	Spring, Scrapers	1	J8131
5	Nut, Hex, 3/8-16, PLT, Lock	1	J1025
6	Screw, 3/8 - 16, 1.25", PLT, Gr. 5, HHCS	1	J0616

## COMPLETE DOUBLE DISC OPENER BLADE ASSEMBLY - R522045

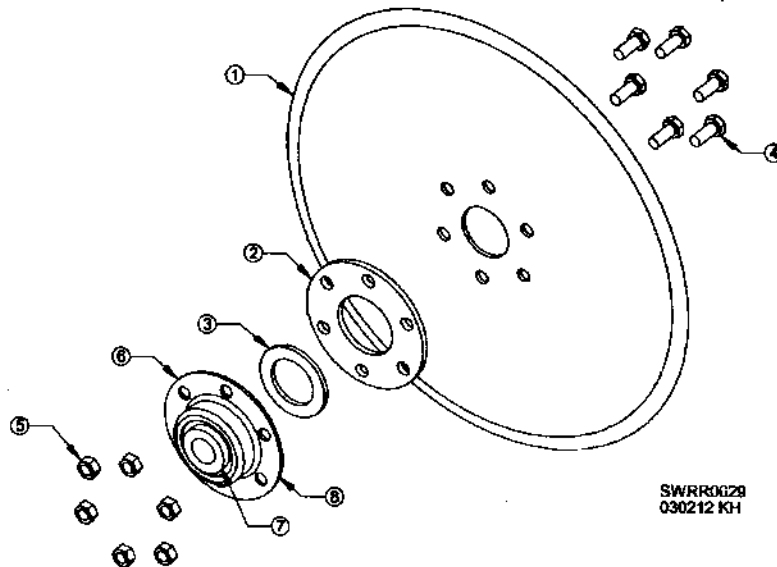

REF. #	DESCRIPTION	QTY	COMP. #
1	Blade, Disc, 13"	1	K5577
2	Plate, Bearing D/O 1980	1	R105009
3	Bushing, Machine, 1-3/8-10Ga. Narrow Rim	1	J1275
4	Screw, 5/16-18, 3/4" PLT	6	J0520
5	Nut, Lock, 5/16-18, PLT	6	J1010
6	Bearing, 3/4" ID, with Flange	1	J00541
7	Bearing Only	1	J0054
8	Flange Only	1	J00064

# LIFT WHEEL HUB ASSEMBLY

5-BOLT - J7280  
6-BOLT - J72352

SWSH0019  
000509BDW

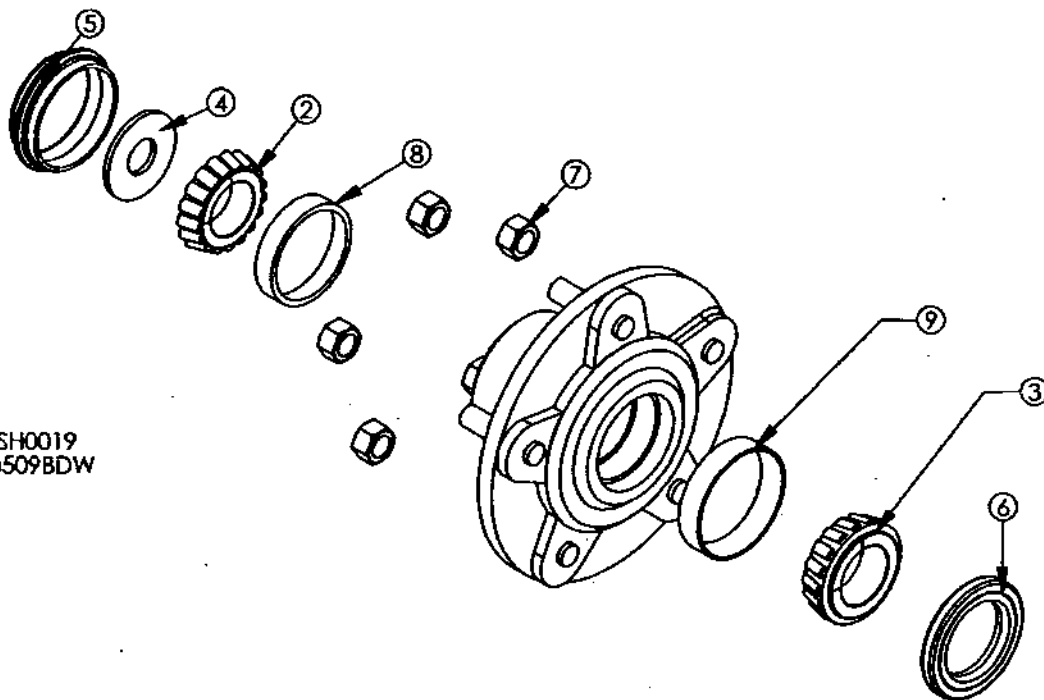

## 5-BOLT

## 6-BOLT

REF. #	DESCRIPTION	QTY	COMP. #	QTY	COMP. #
1	Hub W/Studs	1	J72801	1	J72325
2	Bearing, 1.25, .66 Tapered	1	J0140	1	J0140
3	Bearing, Tapered	1	J0113	1	J0140
4	Washer, Flat, 3/4"	1	J1130	1	J1130
5	Dust Cover, 2-7/16, OD	1	J72331	1	R302014
6	Seal, 1.75 x 2.722, C/R, 17617 HB18	1	J7018	1	J7018
7	Nut, Wheel, 1/2-20, PLT, 60	5	J1043	5	J1043
8	Cup, 1.25, Bearing	1	J0141	1	J0141
9	Cup, Wheel Bearing	1	J0114	1	J01255



# GRASS SEED ASSEMBLY (OPTIONAL) 7', 10', & 12'

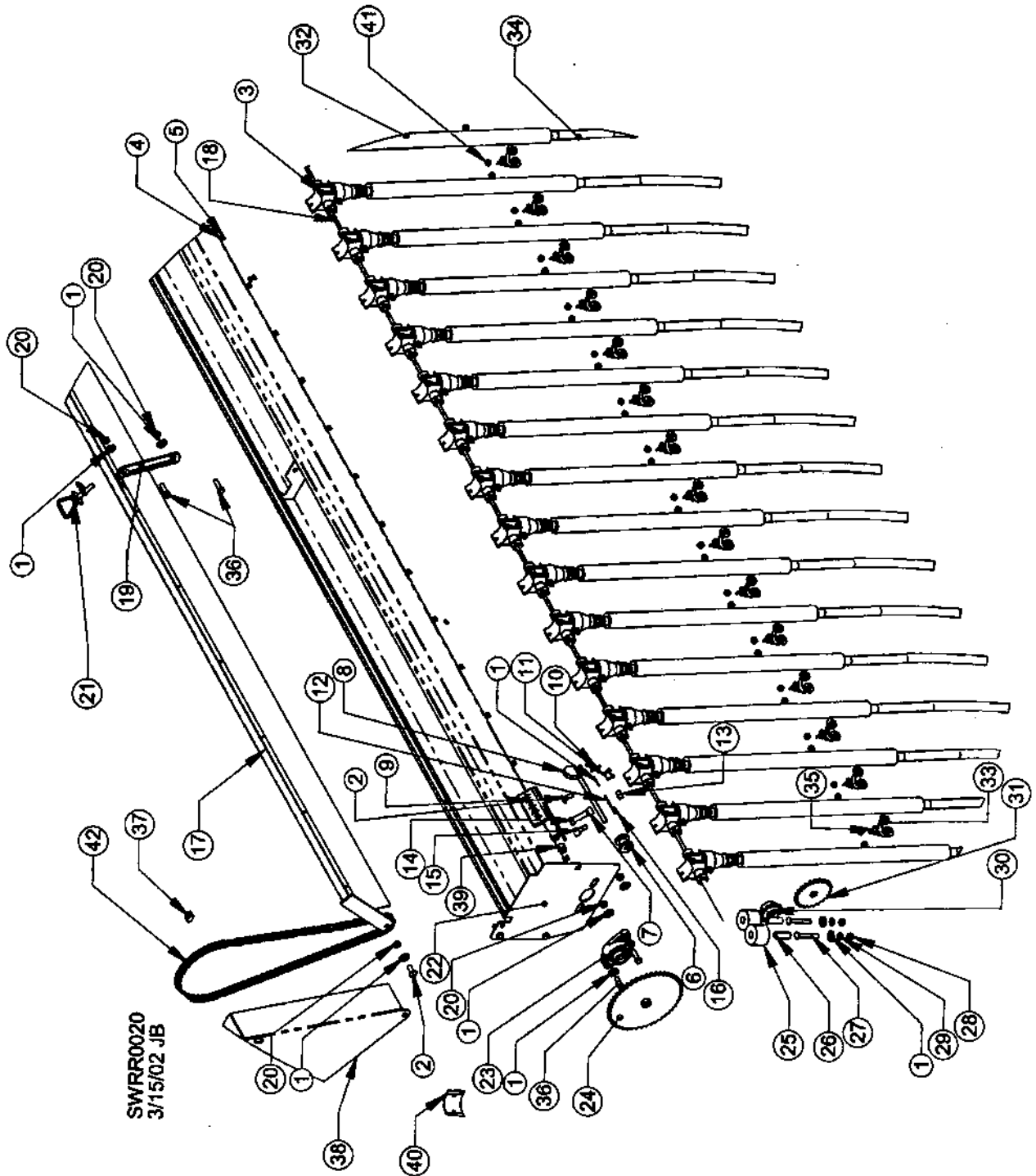

SWRR0020  
3/15/02 JB

# GRASS SEED ASSEMBLY (OPTIONAL)

## 7', 10', & 12'

REF. #	DESCRIPTION	7FT		10FT		12FT	
		QTY	COMP. #	QTY	COMP. #	QTY	COMP. #
1	Washer, Flat, 3/8", PLT	47	J1117	47	J1117	47	J1117
2	Bolt, Carriage, 3X1"	3	J06064	3	J06064	3	J06064
3	Meter, Grass Seed, Assembly, Without Chute	12	R522449	18	R522449	20	R522449
4	Screw, 1/4-20, 1/2PLT, Gr. 5, HHCS	26	J0504	38	J0504	40	J0504
5	Nut, Lock, 1/4-20, PLT	28	J0992	40	J0992	40	J0992
6	Spool, Meter, Adjustment	1	RR1119	1	RR1119	1	RR1119
7	Spacer, Medium, Swivel	1	RR1105	1	RR1105	1	RR1105
8	Handle Meter Adjustment, 3 to 1	1	RR1121	1	RR1121	1	RR1121
9	Plate, Gauge, Lever Adjustment	1	L0845	1	L0845	1	L0845
10	Pin, Roll, 5/32, 1", PLT	1	J1480	1	J1480	1	J1480
11	Nut, Wing, 3/8-16 PLT	1	J1022	1	J1022	1	J1022
12	Washer, Flat, 1/2" - 13, PLT, Gr. 8	1	J1125	1	J1125	1	J1125
13	Nut, Lock, 1/2"	1	J1042	1	J1042	1	J1042
14	Screw, 1/2-13, 1.5, Gr. 5 HHCS, PLT	1	J0730	1	J0730	1	J0730
15	Bearing, Cam Follower, .75 CF, 3/4S	1	J0035	1	J0035	1	J0035
16	Nut, Hex, 3/8-24, PLT Fine Thread	1	J1030	1	J1030	1	J1030
17	Lid, Grass Seeder, Weldment	1	RR1304	1	RR1321	1	RR1422
18	Drive Shaft, Hopper, Grass Seeder	1	RR1307	1	RR1323	1	RR1424
19	Bracket, Slide	1	RR1125	1	RR1125	1	RR1125
20	Nut, Hex, Lock, 3/8-16, PLT, Gr. A	10	J1025	10	J1025	10	J1025
21	Latch, Bail Handle	1	J23010	1	J23010	1	J23010
22	Hopper, Grass Seeder, Weldment	1	RR1320	1	RR1302	1	RR1423
23	Bearing, 1", Flange, W/Collar	1	J0003	1	J0003	1	J0003
24	Sprocket, Weldment, 47 Tooth	1	RR1324	1	RR1324	1	RR1324
25	Roller Chain Tightner	2	R6732	2	R6732	2	R6732
26	Bushing, Plastic Chain Tightner	2	R6733	2	R6733	2	R6733
27	Bolt, Carriage, 3/8" x 2-1/2"	2	J0656	2	J0656	2	J0656
28	Nut, Hex, 3/8-16, PLT	2	J1020	2	J1020	2	J1020
29	Washer, Lock, 3/8, PLT, Split	2	J1205	2	J1205	2	J1205
30	Sprocket, 40B13, .890 Hex Bore	1	R6590	1	R6590	1	R6590
31	Sprocket, 40B23, .890 Hex Bore, GA5108	1	J16482	1	J16482	1	J16482
32	Tube, Small Seed, 3/4"	12	J7363	18	J7363	20	J7363
33	U-Bolt, 5/16-18, 1-1/16"ID, 1.75D	12	J0810	18	J0810	20	J0810
34	Tube, Grass Seed	12	RR1332	18	RR1332	20	RR1332
35	Clamp, Hose Spring Type, 1"	12	J7364	18	J7364	20	J7364
36	Screw, 3/8-16, 1.25", PLT, Gr. 5, HHCS	2	J0616	2	J0616	2	J0616
37	Chain, 100 Links, #40	1	R624188	1	R624188	1	R624188
38	Connector, Chain, Link, #40	1	J1745	1	J1745	1	J1745
39	Shield, Grass Seeder	1	RR1328	1	RR1328	1	RR1328
40	Shaft Collar, 1/2"	2	M3709	2	M3709	2	M3709
41	Plug, Hole G/S #2	1	R124072	1	R124072	1	R124072
42	Nut, Lock, 5/16-18, PLT	36	J1010	36	J1010	36	J1010

# SMALL SEED METER

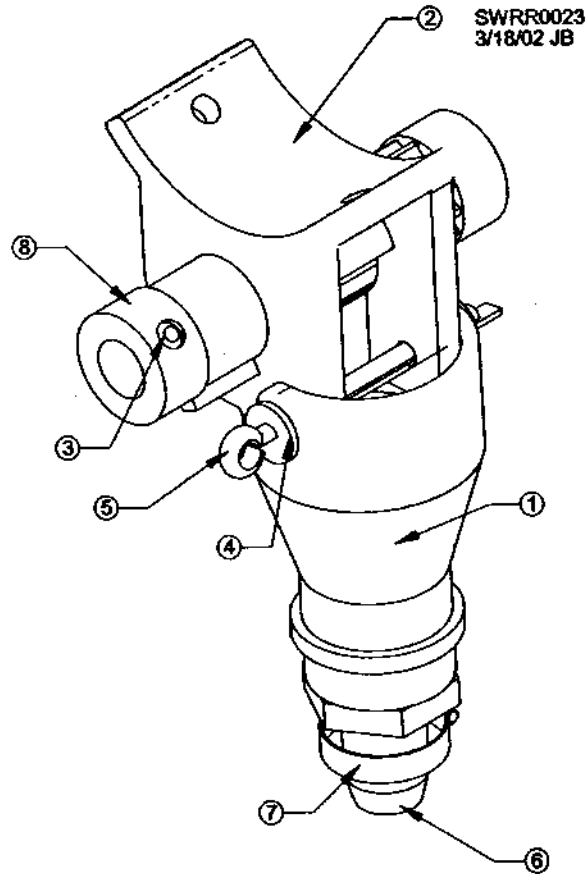

REF. #	DESCRIPTION	QTY	COMP. #
1	Barlet, Swivel, Threaded	1	R820015
2	Seed Meter, GS, Housing, Roller, Bushing	1	R522458
3	Setscrew, 1/4-20 x 1/4", Soc. Head	2	J1074
4	Washer, Flat, 3/16, PLT	2	J1100
5	Pin, Cotter, 3/16, 2-1/2", PLT	1	J1437
6	Hose, Barb, Plastic, 3/4", Male NPS	1	J7365
7	Hose Clamp, 5/8-1", #5	1	J23192
8	Shaft, Collar, 1/2"	2	M3709

# SEED METER ASSEMBLY

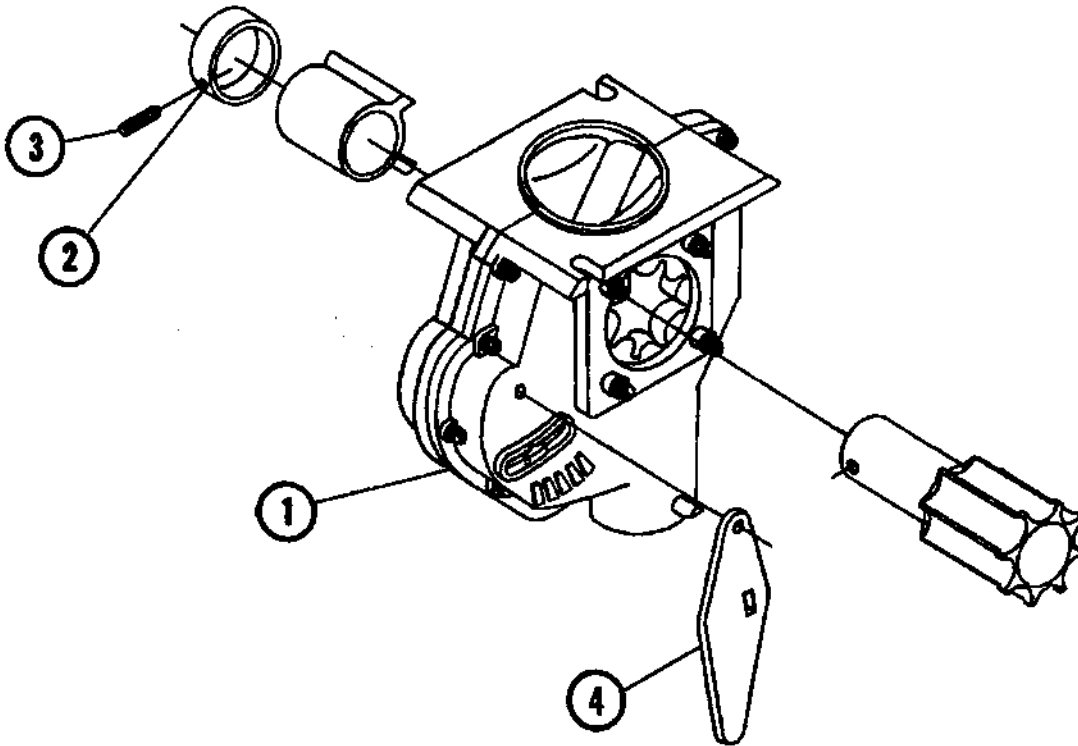

REF. #	DESCRIPTION	QTY	COMP. #
1	Seed Meter Assembly (Includes Ref. #4)	1	J8120
2	Lock Collar	1	R6565
3	Setscrew, 1/4-20, 1/2" SH	1	J1075
4	Lever, Seed Cup Gate	1	J8120-03

# NATIVE GRASS SEEDER (OPTIONAL)

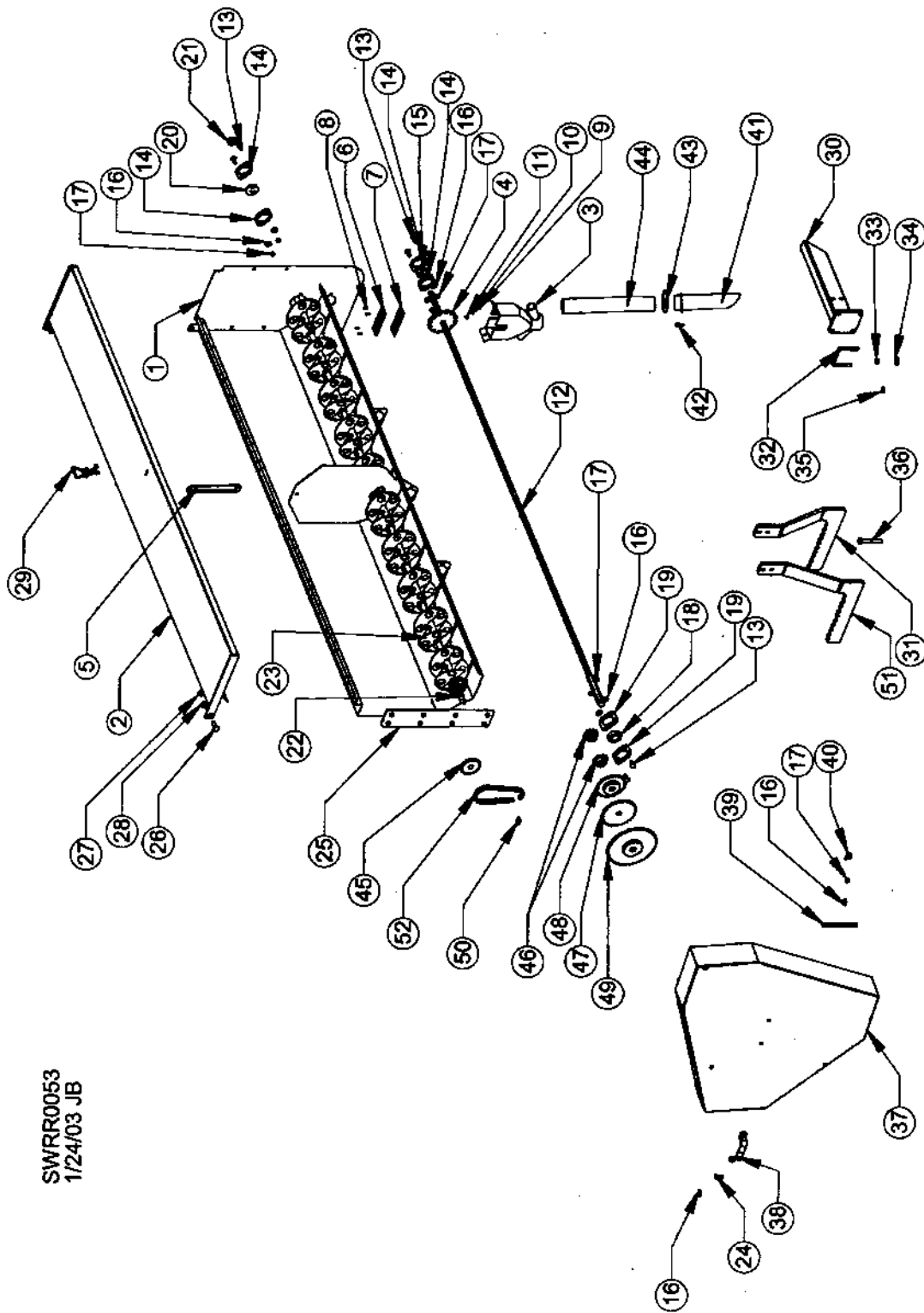

SWRR0053  
1/24/03 JB

## NATIVE GRASS SEEDER (OPTIONAL)

7'

10'

REF. #	DESCRIPTION	QTY	COMP. #	QTY	COMP. #
1	Hopper Weldment	1	RR1375	1	RR1369
2	Hopper Lid Weldment	1	RR1378	1	RR1370
3	Meter Housing, NGS	10	J8110	16	J8110
4	Picker Wheel NGS	10	J8112	16	J8112
5	Slide Latch	1	R6694	1	R6694
6	Rubber Seal Retainer	10	RR1372	16	RR1372
7	Rubber Gasket, Picker Wheel	10	J8109	16	J8109
8	Rivet, Pop, 3/16 x 3/8, #66	40	J1599	64	J1599
9	Bolt, 1/4-20 x 3/4	20	J0505	20	J0505
10	Washer, Lock, 1/4, PLT	20	J1195	32	J1195
11	Nut, hex, 1/4-20	20	J0990	20	J0990
12	Drive Shaft Meter Drive Weldment	1	RR1380	1	RR1373
13	Bolt, Carriage, 5/16 x 1"	14	J0535	14	J0535
14	Flangette	12	J0099	14	J0099
15	Bearing, Flangette, 1/2" Sq.	3	J8108	4	J8108
16	Washer, Flat, 3/8, PLT	38	J1117	38	J1117
17	Nut, Hex, 3/8-16, PLT Lock	35	J1025	35	J1025
18	Bearing, 1", Center, FH205-16 W/L CLR	1	J0005	1	J0005
19	Flangette	2	J00985	2	J00985
20	Bearing, Self-Aligning	3	J00062	3	J00062
21	Locking Collar, 3/4"	3	J0053	3	J0053
22	Drive Shaft, Agitator	1	RR1379	1	RR1376
23	Agitator Weldment	10	RR1377	16	RR1377
24	Screw, 3/8-16, 1, PLT	28	J0606	28	J0606
25	Bracket Mounting	2	RR1374	2	RR1374
26	Bolt, 1/2-13, 1.5, PLT, Gr. 5, Carriage	2	J0739	2	J0739
27	Nut, Lock, 1/2-13	6	J1042	6	J1042
28	Washer, flat, 1/2"	2	J1125	2	J1125
29	Latch, Bail Handle	1	J23010	1	J23010
30	Walk Support Weldment	3	RR1382	3	RR1382
31	Step	1	RR1383	1	RR1383
32	U-Bolt, 7/16-14, PLT	6	J08393	6	J08393
33	Nut, Hex, 7/16-14, PLT	12	J1035	12	J1035
34	Washer, Flat, 7/16", PLT	12	J1120	12	J1120
35	Washer, Lock, 7/16, PLT, split	12	J1210	12	J1210
36	Screw, 1/2-13, 3-1/2, Gr. 5, HHCS	4	J0754	4	J0754
37	Nut, Wing, 3/8-16, 4, PLT, Gr. 5, HHCS	1	RR1381	1	RR1381
38	Handle, Pull, V4, VA Fans	1	J3232	1	J3232
39	Screw, 3/8-16, 4, PLT, Gr. 5, HHCS	3	J06865	3	J06865
40	Nut, Wing, 3/8-16, PLT	3	J1022	3	J1022
41	Tube Weldment, Native Grass	10	RR1366	16	RR1366
42	Screw, 1/4-14, 1, PLT, Selfdrill	21	J0501	32	J0501
43	Clamp, Hose, 1-13/16 x 2-3/4"	20	J2321	32	J2321
44	Seed Tube, Native Grass	10	J7366	32	J7366
45	Sprocket, 40B, 25 tooth, 3/4" Bore, Keyed	1	J1638	1	J1638
46	Sprocket, 40B13, Hex Bore	2	R6590	2	R6590
47	Sprocket, 40B33, .890 Hex Bore, GA5115	1	J16484	1	J16484
48	Sprocket, 40B, 28tooth, Hex Bore	1	J1654	1	J1654
49	Sprocket, 40B, 48tooth, Hex Bore	1	R6589	1	R6589
50	Chain, Link, #40 Connector	1	J1745	1	J1745
51	Step	1	RR1460	1	RR1460
52	Chain, #40, 39 Links	1	R624191	1	R624191

## NATIVE (WARM SEASON) GRASS SEEDER

The seeds planted with this type of seed box may have highly varying amounts of trash or inert material mixed in with the actual seed. The amount of seed that will actually germinate will also differ with each seed lot. Recommended planting rates are based on the amount of Pure Live Seed (PLS), or seed that will actually grow. To calculate how much to plant, use the following formula.

$$\text{Actual Seeding Rate (lbs/acre)} = \frac{\text{Desired Rate of PLS}}{(1 - \% \text{ Inert Material}) \times (\% \text{ Germination})}$$

Note: Percentages should be in decimal form.

**Example:** Plant a desired seed rate of 10lbs/ac of Pure Live Seed. The seed has 40% inert material and a 75% germination rate. What actual seeding rate should be planted?

$$\text{Actual Seeding Rate} = \frac{10\text{lbs/ac}}{(1 - .40) \times (.75)} = 22.2\text{lbs/ac}$$

To set the drill, start with one of the middle sprocket settings. Seed charts are not practical due to the large variation in seed lots. Follow the Calibration Procedure on page 23 of this manual. It is recommended that you catch seed from the entire width of the drill to get enough seed to weigh with fewer turns of the drive wheel. Adjust the sprocket setting up or down to get as close as possible to your Actual Seeding Rate.

## Native Grass Seed Hopper

### Standard Sprocket Ratios

Seed charts are not possible due to  
the large variation in seed sizes.

Setting #	Jack Shaft	Meter Shaft	# of Chain Links
1	13 tooth	60 tooth	79 + 9 + 13
2	15 tooth	60 tooth	
3	13 tooth	48 tooth	79 + 9 + 7
4	15 tooth	48 tooth	
5	13 tooth	33 tooth	79 + 9
6	15 tooth	33 tooth	
7	33 tooth	60 tooth	79 + 9 + 7 + 13
8	33 tooth	48 tooth	79 + 9 + 13 + 1/2
9	13 tooth	15 tooth	79
10	15 tooth	13 tooth	

The lower the setting # the lower the seeding rate.

The higher the setting # the higher the seeding rate.

Calibrate drill to the seed you are using with the following formula:

$$\text{Seeding Rate (lbs/acre)} = \frac{5609 \times S}{N \times W}$$

Where:

S = Sample weight in ounces

N = Number of turns of drive wheel

W = Width of swath you are catching in inches

3 openers on 7 1/2" spacing = 22.5"

10 openers on 7 1/2" spacing = 75"